

GENERAC®

POWER SYSTEMS, INC.

Installation, Start-up and Adjustment Manual

GUARDIAN™

by **GENERAC®** POWER SYSTEMS
Air-cooled, Prepackaged
Standby Generators

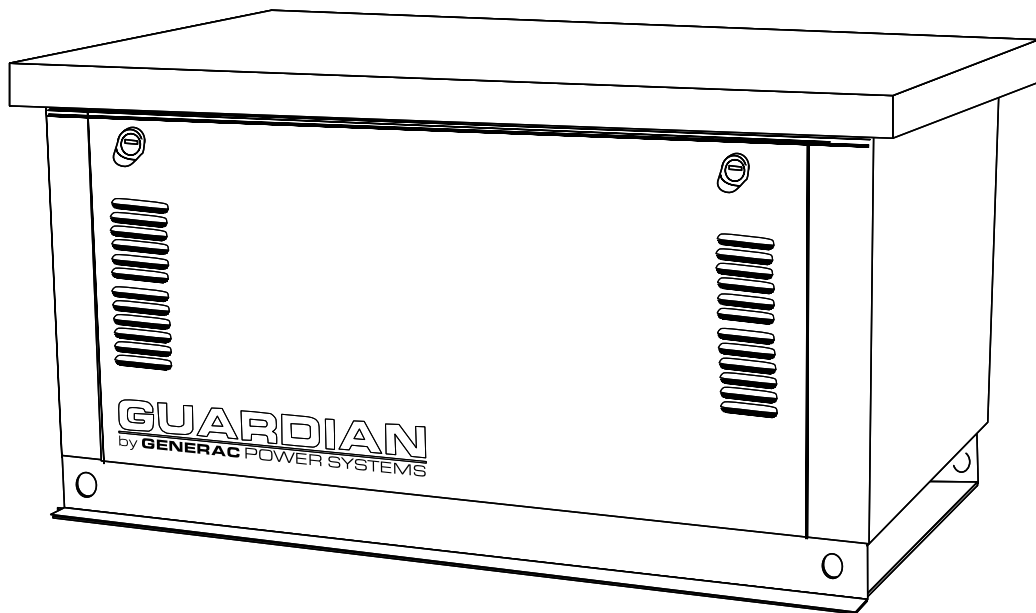

—▲ **DANGER** ▲—

ONLY QUALIFIED ELECTRICIANS OR CONTRACTORS
SHOULD ATTEMPT INSTALLATION!!

INTRODUCTION

Thank you for purchasing a model of the Guardian product line by Generac Power Systems Inc. These models are compact, high performance, air-cooled, engine-driven generators designed to automatically supply electrical power to operate critical loads during a utility power failure.

This unit is factory installed in an all-weather, metal enclosure that is intended exclusively for outdoor installation. This generator will operate using either vapor withdrawn liquid propane (LP) or natural gas (NG).

◆ READ THIS MANUAL THOROUGHLY

If you do not understand any portion of this manual, contact Generac or your nearest Generac/Guardian Authorized Dealer for starting, operating and servicing procedures.

Throughout this publication, and on tags and decals affixed to the generator, DANGER, WARNING, CAUTION and NOTE blocks are used to alert you to special instructions about a particular operation that may be hazardous if performed incorrectly or carelessly. Observe them carefully. Their definitions are as follows:



After this heading, you can read instructions that, if not strictly complied with, will result in personal injury or property damage.



After this heading, you can read instructions that, if not strictly complied with, may result in personal injury or property damage.



After this heading, you can read instructions that, if not strictly complied with, could result in damage to equipment and/or property.

NOTE:

After this heading, you can read explanatory statements that require special emphasis.

These safety warnings cannot eliminate the hazards that they indicate. Common sense and strict compliance with the special instructions while performing the service are essential to preventing accidents.

Four commonly used safety symbols accompany the DANGER, WARNING and CAUTION blocks. The type of information each indicates follows:

 This symbol points out important safety information that, if not followed, could endanger personal safety and/or property of you and others.

 This symbol points out potential explosion hazard.

 This symbol points out potential fire hazard.

 This symbol points out potential electrical shock hazard.

The operator is responsible for proper and safe use of the equipment. We strongly recommend that the operator read the *Owner's Manual* and thoroughly understand all instructions before using this equipment. We also strongly recommend instructing other users to properly start and operate the unit. This prepares them if they need to operate the equipment in an emergency.

◆ OPERATION AND MAINTENANCE

It is the operator's responsibility to perform all safety checks, to make sure that all maintenance for safe operation is performed promptly, and to have the equipment checked periodically by a Generac/Guardian Authorized Dealer. Normal maintenance service and replacement of parts are the responsibility of the owner/operator and, as such, are not considered defects in materials or workmanship within the terms of the warranty. Individual operating habits and usage contribute to the need for maintenance service.

Proper maintenance and care of your generator ensure a minimum number of problems and keep operating expenses at a minimum. See your Generac/Guardian Authorized Dealer for service aids and accessories.

◆ HOW TO OBTAIN SERVICE

When your generator requires servicing or repairs, simply contact a Generac/Guardian Authorized Dealer for assistance. Service technicians are factory-trained and are capable of handling all of your service needs.

When contacting a Generac/Guardian Authorized Dealer or the factory about parts and service, always supply the complete model number and serial number of your unit as given on its data decal, which is located on the generator's engine.

AUTHORIZED DEALER LOCATION

To locate the GENERAC/GUARDIAN AUTHORIZED
DEALER nearest you, please call this number:

1-800-747-1530

DEALER LOCATION INFORMATION
CAN BE OBTAINED AT THIS NUMBER.

Introduction Inside Front Cover	
Read This Manual Thoroughly	IFC
Operation and Maintenance.....	IFC
How to Obtain Service.....	IFC
Authorized Dealer Location Number.....	IFC
Safety Rules	2
Section 1 – Installation	4
1.1 Introduction to Installation	4
1.1.1 Installation Assistance.....	4
1.1.2 Standards Index	4
1.2 Unpacking.....	4
1.2.1 Precautions	4
1.2.2 Inspection	4
1.3 Before Installation.....	5
1.4 Lifting the Generator.....	5
1.5 Engine Oil Recommendations	5
1.6 Gaseous Fuel System	5
1.6.1 Fuel System Requirements and Recommendations	5
1.6.2 Fuel Consumption	6
1.6.3 Fuel Pipe Sizing.....	6
1.6.4 Reconfiguring the Fuel System	6
1.7 Location and Mounting	7
1.7.1 Generator	7
1.7.2 Transfer Switch.....	7
1.7.2.1 6 Kw, 8 kW and 10 kW Units	7
1.7.2.2 Sound Attenuated Units	7
1.8 Emergency Circuit Isolation Method	11
1.9 Total Circuit Isolation Method.....	11
1.10 Generator AC Connection System	12
1.11 Wiring Interconnections	12
1.11.1 6 kW, 8 kW and 10 kW Units	12
1.11.2 Sound Attenuated Units	12
1.12 Generators and GTS Transfer Switches	14
1.13 Control Circuit Interconnections.....	14
1.14 Adapting Three-phase Transfer Switch	15
1.15 Control Board Configuration.....	15
1.16 Grounding the Generator	15
1.17 The Battery.....	16
1.17.1 Battery Installation	17
1.18 The Fuse.....	17
1.19 Post Installation Inspection	17
Section 2 – Operation	18
2.1 Using the Auto/Off/Manual Switch.....	18
2.1.1 “Auto” Position.....	18
2.1.2 “Off” Position.....	18
2.1.3 “Manual” Position	18
2.2 Automatic Transfer Operation.....	18
2.3 Sequence of Automatic Operation	19
2.4 Manual Transfer Operation.....	19
2.4.1 Transfer to Generator Power Source	19
2.4.2 Transfer Back to Utility Power Source	20
2.5 Protection Systems	20
2.5.1 Low Oil Pressure Switch	20
2.5.2 High Temperature Switch	20
2.5.3 Overcrank	20
2.5.3.1 Approximate Crank Cycle Times	21
2.5.4 Overspeed	21
2.6 Additional Generator Features	21
2.6.1 6 kW, 8 kW and 10 kW Units	21
2.6.2 Sound Attenuated Units	21
Section 3 – Post-installation Start-up Adjustments	22
3.1 Before Initial Start-up	22
3.2 Check Transfer Switch Operation	22
3.3 Electrical Checks	22
3.4 Generator Tests Under Load.....	22
3.5 Checking Automatic Operation	23
3.6 Adjusting the Load Block	23
3.7 Engine Governor Adjustment	24
3.7.1 6 kW Units	24
3.7.2 8 kW and 10 kW Units	24
3.7.3 Sound Attenuated Units	25
3.8 Voltage Regulator Adjustment	25
3.9 Overspeed Calibration.....	25
3.9.1 6 kW, 8 kW and 10 kW Units	26
3.9.2 Sound Attenuated Units	26
3.10 Setting the Exercise Timer	26
3.10.1 6 kW, 8 kW and 10 kW Units	26
3.10.2 Sound Attenuated Units	26
Section 4 – Troubleshooting	27
4.1 Troubleshooting Guide	27
4.2 Installation Checklist	28
Section 5 – Electrical Data	29



SAVE THESE INSTRUCTIONS - The manufacturer suggests that these rules for safe operation be copied and posted near the unit's installation site. Safety should be stressed to all operators and potential operators of this equipment.

**WARNING:**

The engine exhaust from this product contains chemicals known to the state of California to cause cancer, birth defects or other reproductive harm.

Study these SAFETY RULES carefully before installing, operating or servicing this equipment. Become familiar with this *Installation, Start-up and Adjustment Manual* and with the unit. The generator can operate safely, efficiently and reliably only if it is properly installed, operated and maintained. Many accidents are caused by failing to follow simple and fundamental rules or precautions.

Generac cannot possibly anticipate every possible circumstance that might involve a hazard. The warnings in this manual, and on tags and decals affixed to the unit are, therefore, not all-inclusive. If you use a procedure, work method or operating technique Generac does not specifically recommend, you must satisfy yourself that it is safe for you and others. You also must make sure the procedure, work method or operating technique that you choose does not render the generator unsafe.

—  **DANGER**  —

 Despite the safe design of this generator, operating this equipment imprudently, neglecting its maintenance or being careless can cause possible injury or death. Permit only responsible and capable persons to operate or maintain this equipment.

 Potentially lethal voltages are generated by these machines. Ensure all steps are taken to render the machine safe before attempting to work on the generator.

 Parts of the generator are rotating and/or hot during operation. Exercise care near running generators.

**GENERAL HAZARDS**

- For safety reasons, Generac recommends that the installation, initial start-up and maintenance of this equipment is carried out by a Generac/Guardian Authorized Dealer.
- The engine exhaust fumes contain carbon monoxide, which can be DEADLY. This dangerous gas, if breathed in sufficient concentrations, can cause unconsciousness or even death. This exhaust system must be installed properly, in strict compliance with applicable codes and standards. Following installation, you must do nothing that might render the system unsafe or in noncompliance with such codes and standards.
- Keep hands, feet, clothing, etc., away from drive belts, fans, and other moving or hot parts. Never remove any drive belt or fan guard while the unit is operating.
- Adequate, unobstructed flow of cooling and ventilating air is critical to correct generator operation. Do not alter the installation or permit even partial blockage of ventilation provisions, as this can seriously affect safe operation of the generator. The generator MUST be installed outdoors.
- When working on this equipment, remain alert at all times. Never work on the equipment when you are physically or mentally fatigued.
- Inspect the generator regularly, and contact your nearest Generac/Guardian Authorized Dealer for parts needing repair or replacement.
- Before performing any maintenance on the generator, disconnect its battery cables to prevent accidental start up. Disconnect the cable from the battery post indicated by a NEGATIVE, NEG or (-) first. Reconnect that cable last.
- Never use the generator or any of its parts as a step. Stepping on the unit can stress and break parts, and may result in dangerous operating conditions from leaking exhaust gases, fuel leakage, oil leakage, etc.



ELECTRICAL HAZARDS

- All generators covered by this manual produce dangerous electrical voltages and can cause fatal electrical shock. Utility power delivers extremely high and dangerous voltages to the transfer switch as does the standby generator when it is in operation. Avoid contact with bare wires, terminals, connections, etc., while the unit is running. Ensure all appropriate covers, guards and barriers are in place before operating the generator. If you must work around an operating unit, stand on an insulated, dry surface to reduce shock hazard.
- Do not handle any kind of electrical device while standing in water, while barefoot, or while hands or feet are wet. **DANGEROUS ELECTRICAL SHOCK WILL RESULT.**
- The National Electrical Code (NEC) requires the frame and external electrically conductive parts of the generator to be connected to an approved earth ground. Local electrical codes also may require proper grounding of the generator electrical system.
- After installing this home standby electrical system, the generator may crank and start at any time without warning. When this occurs, load circuits are transferred to the STANDBY (generator) power source. To prevent possible injury if such a start and transfer occur, always set the generator's Auto/Off/Manual switch to its OFF position before working on equipment and remove the fuse.
- In case of accident caused by electric shock, immediately shut down the source of electrical power. If this is not possible, attempt to free the victim from the live conductor. **AVOID DIRECT CONTACT WITH THE VICTIM.** Use a nonconducting implement, such as a rope or board, to free the victim from the live conductor. If the victim is unconscious, apply first aid and get immediate medical help.
- Never wear jewelry when working on this equipment. Jewelry can conduct electricity resulting in electric shock, or may get caught in moving components causing injury.

FIRE HAZARDS

- For fire safety, the generator must be installed and maintained properly. Installation always must comply with applicable codes, standards, laws and regulations. Adhere strictly to local, state and national electrical and building codes. Comply with regulations the Occupational Safety and Health Administration (OSHA) has established. Also, ensure that the generator is installed in accordance with the manufacturer's instructions and recommendations. Following proper installation, do nothing that might alter a safe installation and render the unit in noncompliance with the aforementioned codes, standards, laws and regulations.
- Keep a fire extinguisher near the generator at all times. Extinguishers rated "ABC" by the National Fire Protection Association are appropriate for use on the standby electric system. Keep the extinguisher properly charged and be familiar with its use. If you have any question pertaining to fire extinguishers, consult your local fire department.

EXPLOSION HAZARDS

- Do not smoke around the generator. Wipe up any fuel or oil spills immediately. Ensure that no combustible materials are left in the generator compartment, or on or near the generator, as FIRE or EXPLOSION may result. Keep the area surrounding the generator clean and free from debris.
- Gaseous fluids such as natural gas and liquid propane (LP) gas are extremely EXPLOSIVE. Install the fuel supply system according to applicable fuel-gas codes. Before placing the home standby electric system into service, fuel system lines must be properly purged and leak tested according to applicable code. After installation, you must inspect the fuel system periodically for leaks. No leakage is permitted.

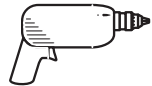

1.1 INTRODUCTION TO INSTALLATION



DANGER:



Only qualified electricians or contractors should attempt such installations, which must comply strictly with applicable codes, standards and regulations.

NOTE:

Read the entire manual before starting the installation.

Generac cannot possibly know of and advise the home standby trade of all conceivable procedures and methods by which installation of this equipment might be achieved. Neither can Generac know of possible hazards and/or results of each method or procedure. We have not undertaken any such wide evaluation.

◆ 1.1.1 INSTALLATION ASSISTANCE

1. For the Homeowner or Business Owner: You need to have a certified electrician or contractor to install this product. To arrange for proper installation, contact one of the following sources:
 - Generac/Guardian Authorized Dealer: Look for “Generac” or “Guardian” in your local Yellow Pages under the classification “Generators – Electric.”
 - Heating and A/C Contractors: Look in your local Yellow Pages under the classifications “Heating Contractors” or “Air Conditioning Contractors.”
 - Call us direct at (414) 544-4811 between the hours of 8 a.m. and 5 p.m. CST. We will gladly assist you in finding a local qualified installer.
2. For the Installing Dealer/Contractor: This manual contains all the information required to properly install and start a Guardian Power Systems generator in most applications. If you do need more information, contact us directly at (414) 544-4811, between the hours of 8 a.m. and 5 p.m., CST.

◆ 1.1.2 STANDARDS INDEX

In the absence of pertinent standards, codes, regulations and laws, the published information listed below may be used as installation guide for this equipment.

1. NFPA No. 37, STATIONARY COMBUSTION ENGINES AND GAS TURBINES, available from the National Fire Protection Association, 470 Atlantic Avenue, Boston, MA 02210.
 2. NFPA No. 76A, ESSENTIAL ELECTRICAL SYSTEMS FOR HEALTH CARE FACILITIES, available same as Item 1.
 3. NFPA No. 54, NATIONAL FUEL GAS CODE, available same as Item 1.
 4. NFPA No. 58, AMERICAN NATIONAL STANDARD FOR STORAGE AND HANDLING OF LIQUEFIED PETROLEUM GAS, available same as Item 1.
- 4 Generac® Power Systems, Inc.

5. NFPA No. 70, NFPA HANDBOOK OF NATIONAL ELECTRIC CODE, available same as Item 1.
6. Article X, NATIONAL BUILDING CODE, available from the American Insurance Association, 85 John Street, New York, N.Y. 10038.
7. AGRICULTURAL WIRING HANDBOOK, available from the Food and Energy Council, 909 University Avenue, Columbia, MO 65201.
8. ASAE EP-3634, INSTALLATION AND MAINTENANCE OF FARM STANDBY ELECTRICAL SYSTEMS, available from the American Society of Agricultural Engineers, 2950 Niles Road, St. Joseph, MI 49085.
9. NFPA No. 30, FLAMMABLE AND COMBUSTIBLE LIQUIDS CODE, available same as Item 1.

1.2 UNPACKING

◆ 1.2.1 PRECAUTIONS

Handle shipping cartons and crates with care. Use care to avoid damage from dropping, bumping, collision, etc. Store and unpack crates and cartons with the proper side up, as noted on the shipping carton.

◆ 1.2.2 INSPECTION

After unpacking, carefully inspect the contents for damage that may have occurred during shipment

- This standby generator set has been factory supplied with a weather protective enclosure that is intended for outdoor installation only.
- The 6 kW, 8 kW and 10 kW standby generator sets are packaged with an automatic transfer switch.
- This UL listed, two-pole switch is rated at 100 AC amperes at 250 volts maximum. This transfer switch is for indoor use only.
- All sound attenuated models have a built-in transfer switch.

—▲ WARNING ▲—



If this generator is used to power electrical load circuits normally powered by a utility power source, you are required by code to install a transfer switch. The transfer switch must effectively isolate the electrical system from the utility distribution system when the generator is operating (NEC 701). Failure to isolate an electrical system by such means will result in damage to the generator and also may result in injury or death to utility power workers due to backfeed of electrical energy.

If any loss or damage is noted at time of delivery, have the person(s) making the delivery note all damage on the freight bill or affix his or her signature under the consignor's memo of loss or damage.

If you note loss or damage after delivery, separate the damaged materials and contact the carrier for claim procedures.

“Concealed damage” is understood to mean damage to the contents of a package that is not in evidence at the time of delivery, but is discovered later.



1.3 BEFORE INSTALLATION

Before installing this equipment, check the ratings of both the generator and the transfer switch. Read “Emergency Circuit Isolation Method” and “Total Circuit Isolation Method” in sections 1.8 and 1.9 carefully.

The generator's rated wattage/amperage capacity must be adequate to handle all electrical loads that the unit will power. You may have to group the critical (essential) electrical loads together and wire them into a separate emergency distribution panel.

NOTE:

In some areas, you may need to acquire electrical permits for installing an emergency system, building permits for installing gas lines, and permits for noise allowances. Check your local codes before installing the unit.

1.4 LIFTING THE GENERATOR

To lift a nonsound attenuated generator, insert pipe having sufficient strength and diameter through the lifting holes (lifting brackets are provided with sound attenuated units), which are located near the unit's base (see Figure 1.1). You also may lift the unit using a hook and hoist method provided you use a spreader bar to ensure that the lines clear the roof.

Figure 1.1 – Location of Lifting Holes/Brackets

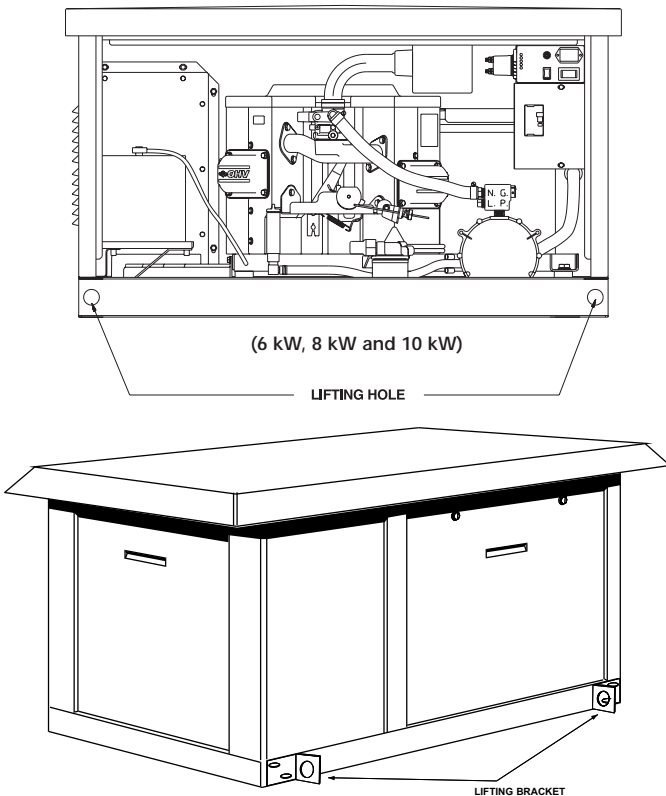

(Sound Attenuated)

WARNING

- ⚠ When lifting or hoisting equipment is used, be careful not to touch overhead power lines.
- ⚠ The generator's weight of more than 300 pounds requires proper tools and equipment, and qualified personnel to be used in all phases of handling and unpacking.
- ⚠ Exercise caution when lifting the unit manually as it may shift on lifting pipes during transportation, which may result in injury.

CAUTION

- ⚠ The generator was not designed to be lifted by its roof. Use the lifting holes or brackets provided near the base of the unit. If using a hook and hoist lifting method, you must employ a spreader bar to prevent from crushing the roof.

1.5 ENGINE OIL RECOMMENDATIONS

Use oil of American Petroleum Institute (API) Service Class SG, SH or SJ. Select the viscosity based on the air temperature at the time of operation. See the following chart:

Temperature	Oil Grade (Recommended)
Above -7° C (20° F)	SAE 10W-30 or SAE 30
Below -7° C (20° F)	SAE 5W-20 or 5W-30
All Seasons	SAE 5W-30 Synthetic*

*Organic break-in oil is required before using synthetic oil.

CAUTION

- ⚠ Any attempt to crank or start the engine before it has been properly serviced with the recommended oil may result in an engine failure.

1.6 GASEOUS FUEL SYSTEM

NOTE:

The following information pertaining to gaseous fuel systems is provided to assist gaseous fuel technicians in planning installations. In no way should this information be interpreted to conflict with applicable fuel gas codes. Consult with your local fuel supplier or fire marshall if questions or problems arise.

◆ 1.6.1 FUEL SYSTEM REQUIREMENTS AND RECOMMENDATIONS

When installing the fuel system, install a flexible length of line between the generator fuel connection and the rigid piping. The flexible hose must be approved for use with gaseous fuels. It is recommended that an emergency manual fuel shutoff valve be placed in-line.

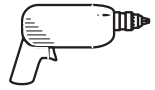

With LP gas, use only the vapor withdrawal system. This type of system uses the vapors formed above the liquid fuel in the storage tank.

The engine has been fitted with a fuel carburetion system that meets the specifications of the 1997 California Air Resources Board for tamper-proof dual fuel systems. The unit will run on natural gas or LP gas, but it has been factory set to run on natural gas. Should the primary fuel need to be changed to LP gas, the fuel system needs to be reconfigured. See section 1.6.4 (page 6) for instructions on reconfiguration of the fuel system.

Recommended fuels should have a Btu content of at least 1,000 Btus per cubic foot for natural gas; or at least 2,520 Btus per cubic foot for LP gas. Ask your fuel supplier for the Btu content of your fuel.

Fuel pressure for both natural gas and liquid propane (LP) vapor set ups **MUST** be 11 inches to 14 inches of water column (0.6 psi) at all load ranges.

◆ 1.6.2 FUEL CONSUMPTION

See the following chart for fuel supply requirements at half and full load for both natural gas and LP vapor.

*Natural gas is in cubic feet per hour.

Model #	Nat. Gas (*)		LP Vapor (**)	
	1/2 Load	Full Load	1/2 Load	Full Load
6 kW	74.1	105.3	0.86/31.30	1.08/39.30
8 kW	79.7	140.0	1.07/38.94	1.56/56.77
10 kW	100.8	177.9	1.16/42.21	2.15/78.24
Sound Attn.	84.6	126.6	1.06/38.57	1.7/61.86

**LP is in gallons per hour/cubic feet per hour.

▲ **WARNING** ▲

▲ Gaseous fuels such as natural gas and liquid propane (LP) gas are highly explosive. Even the slightest spark can ignite such fuels and cause an explosion. No leakage of fuel is permitted. Natural gas, which is lighter than air, tends to collect in high areas. LP gas is heavier than air and tends to settle in low areas.

◆ 1.6.3 FUEL PIPE SIZING

See the following chart for proper sizing of fuel supply piping. Insufficient fuel pipe size can cause hard starting, poor engine performance and inability to carry load.

NG and LP Vapor Pipe Sizing Chart:

Length of Pipe	Iron Pipe Size (IPS Inches)					
	½"	¾"	1"	1 ¼"	1 ½"	2"
15'	76	172	345	750	1,220	2,480
30'	52	120	241	535	850	1,780
45'	43	99	199	435	700	1,475
60'	38	86	173	380	610	1,290
75'		77	155	345	545	1,120
90'		70	141	310	490	1,000
105'		65	131	285	450	920
120'			120	270	420	860
150'			109	242	380	780
180'			100	225	350	720
210'			92	205	320	660
240'				190	300	620
270'				178	285	580
300'				170	270	545
450'				140	226	450
600'				119	192	390

◆ 1.6.4 RECONFIGURING THE FUEL SYSTEM

To reconfigure the fuel system from NG to LP, follow these steps:

1. Remove the carburetor fuel hose from the natural gas port of the fuel load block and the brass fitting (Figure 1.2).
2. Remove the blanking plug from the LP port of the load block (Figure 1.2).

Figure 1.2 – Natural Gas Setup

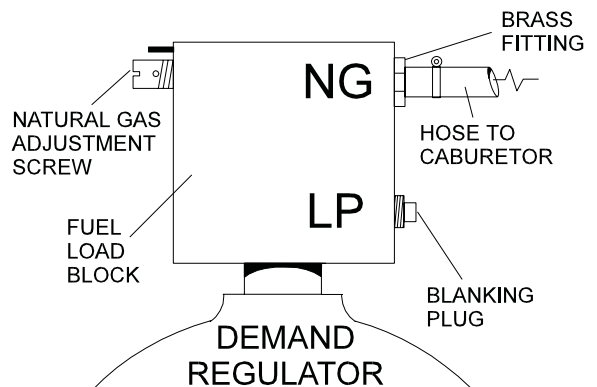



3. Refit the fitting and hose to the LP port and the blanking plug to the natural gas port (Figure 1.3).
4. Reverse the procedure to convert back to natural gas.

NOTE:

The natural gas adjustment screw is preset during installation and should not need any further adjustment.

Figure 1.3 – LP Gas Setup

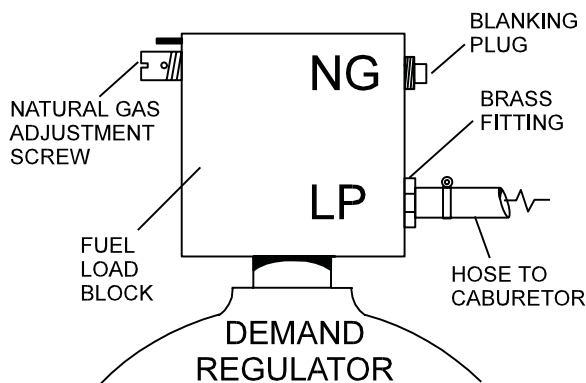

1.7 LOCATION AND MOUNTING

◆ 1.7.1 GENERATOR

Install the generator set, in its protective enclosure, outdoors, where adequate cooling and ventilating air always is available. Consider these factors:

- Install the unit where air inlet and outlet openings will not become obstructed by leaves, grass, snow, etc. If prevailing winds will cause blowing or drifting, you may need to consider using a windbreak to protect the unit.
- Install the generator on high ground where water levels will not rise and endanger it.
- Allow sufficient room on all sides of the generator for maintenance and servicing. A good rule is to allow 3 feet of space on all sides.
- Where strong prevailing winds blow from one direction, face the generator air inlet openings into the prevailing winds.
- Install the generator as close as possible to the transfer switch. This reduces the length of wiring and conduit.
- Install the generator as close as possible to the fuel supply, to reduce the length of piping. **HOWEVER, REMEMBER THAT LAWS OR CODES MAY REGULATE THE DISTANCE.**

Retain the generator compartment to a concrete slab with 1/4-inch masonry type anchor bolts. Be sure the bolts are long enough to retain the compartment. The slab should be at least 3 inches thick and should extend beyond the enclosure to a distance of at least 3 inches on all sides.

See Figure 1.4 (pages 8-9) and Figure 1.5 (page 10) for generator and transfer switch major dimensions.

◆ 1.7.2 TRANSFER SWITCH

1.7.2.1 6kW, 8 kW and 10 kW Units

The transfer switch shipped with this generator is enclosed in a NEMA 1 enclosure. This type of enclosure is intended for indoor use only. Follow these rules:

- Install the transfer switch indoors on a firm, sturdy supporting structure.
- To prevent switch distortion, level the switch if necessary. This can be done by placing washers between the switch enclosure and mounting surface.
- Never install the switch where water or any corrosive substance might drip onto the enclosure.
- Protect the switch at all times against excessive moisture, dust, dirt, lint, construction grit and corrosive vapors.

1.7.2.2 Sound Attenuated Units

All sound attenuated models have a transfer switch built into the enclosure and do not require a separate switch attachment.

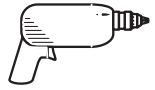

Figure 1.4 – Generator and Transfer Switch Mounting Dimensions (6 kW, 8 kW and 10 kW)

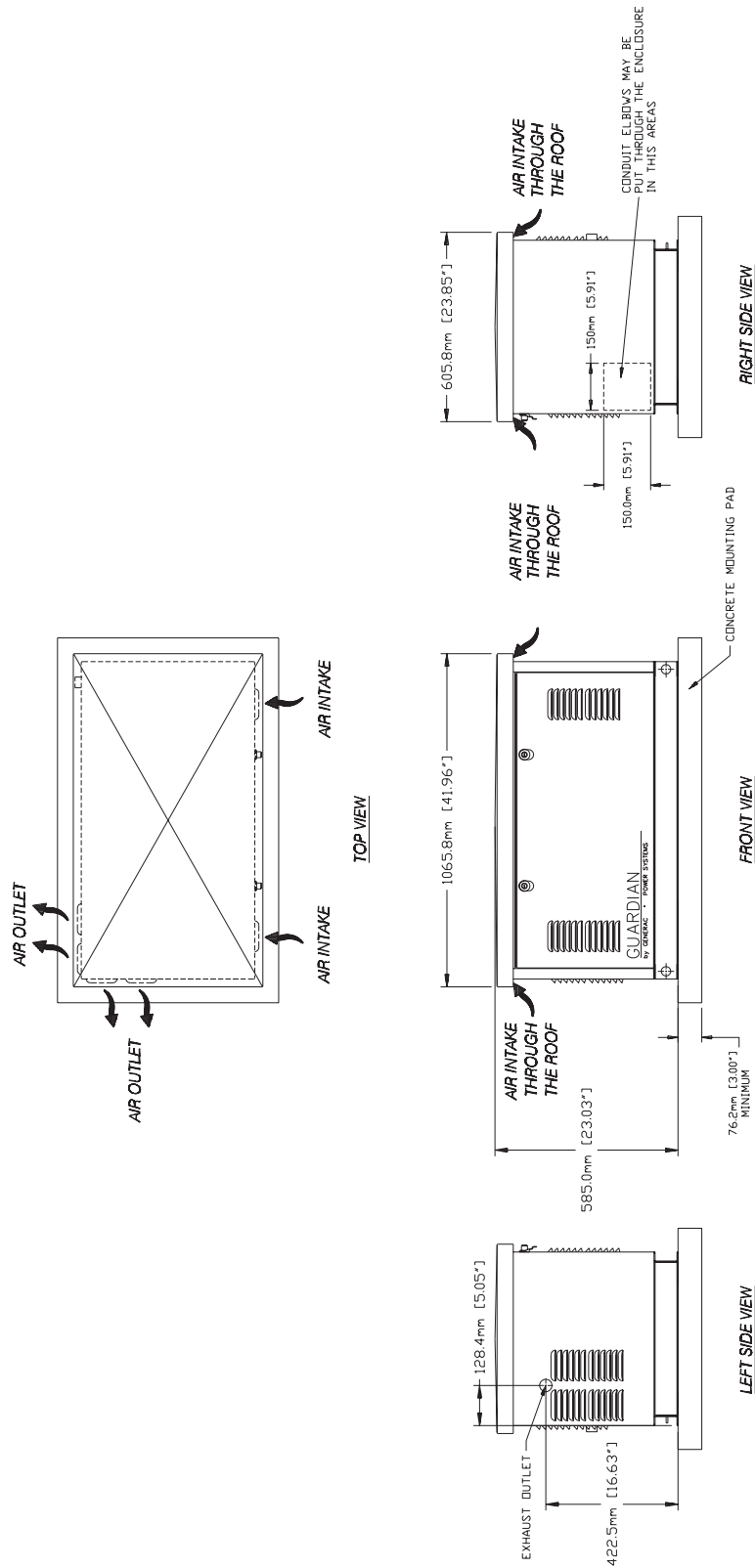
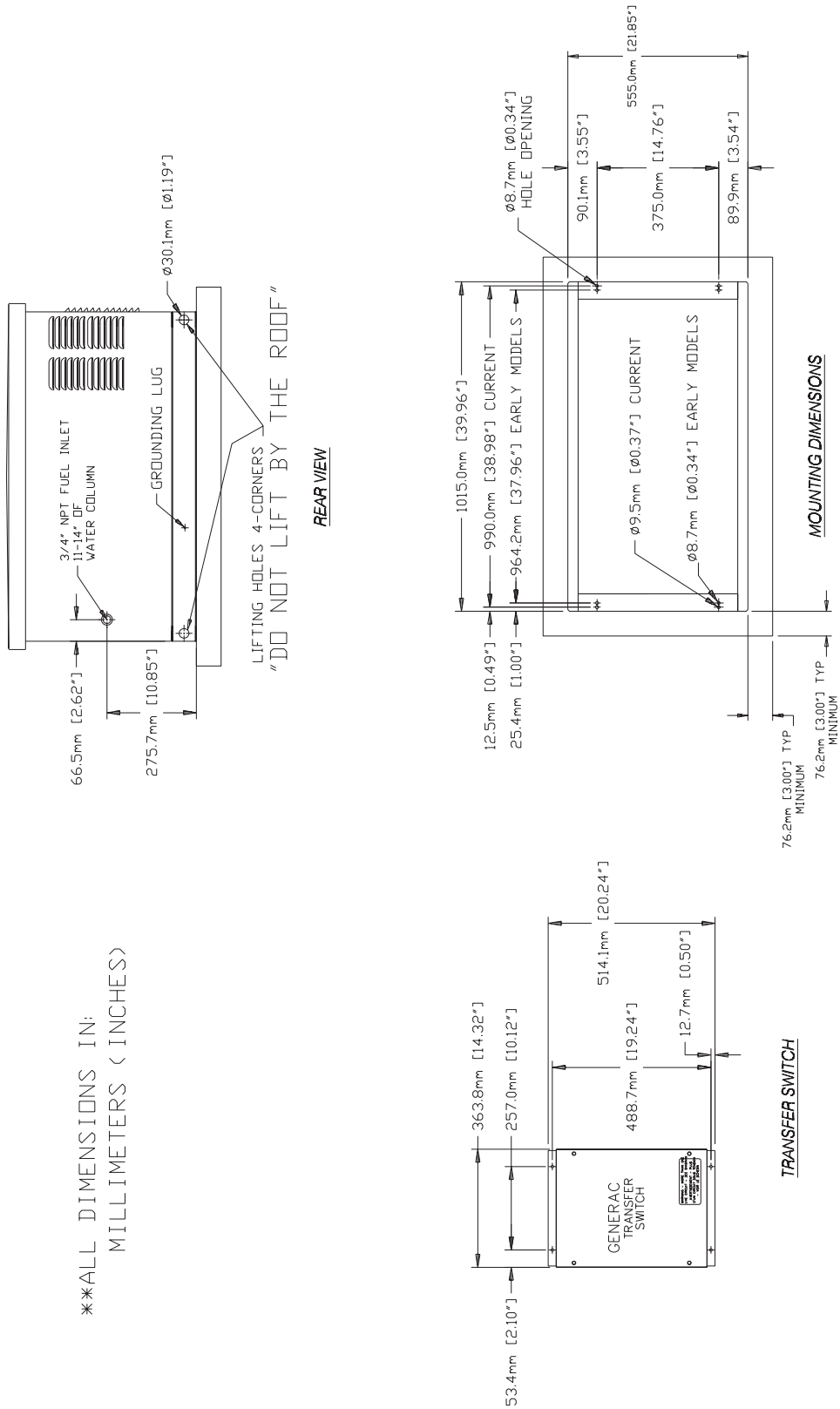



Figure 1.4 (Continued)



**ALL DIMENSIONS IN:
MILLIMETERS < INCHES >

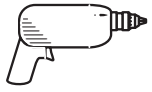
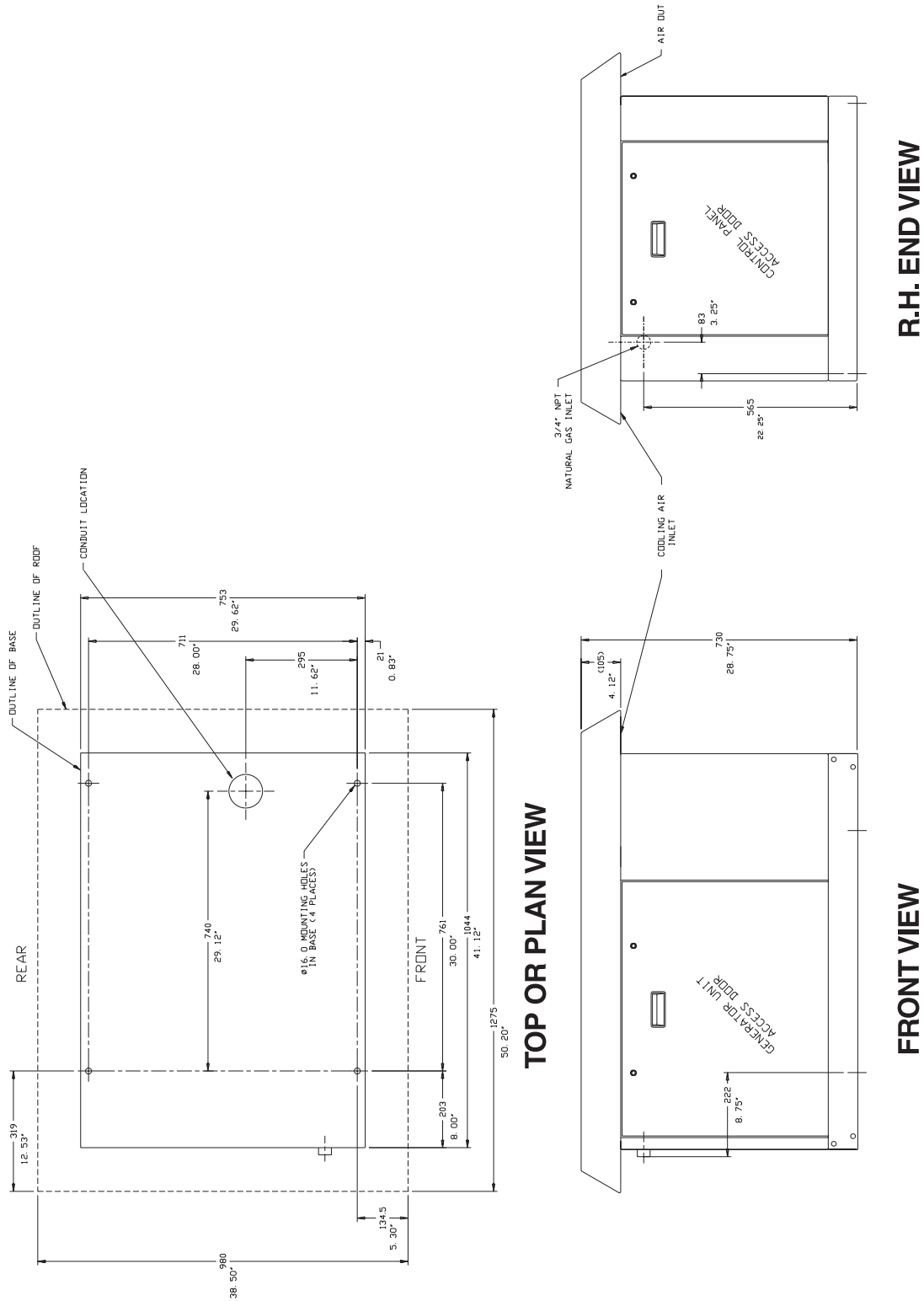

Figure 1.5 – Generator Mounting Dimensions (Sound Attenuated)





1.8 EMERGENCY CIRCUIT ISOLATION METHOD

One effective way of preventing the generator from being overloaded is to use the “Emergency Circuit Isolation Method” (Figure 1.6).

Essential electrical loads are grouped together and wired into a separate emergency distribution panel. Load circuits fed by the emergency distribution panel must be within the unit's rated wattage capacity. The following apply to this type of isolation system:

- The transfer switch is installed between the main and the emergency distribution panels as shown.
- The transfer switch must have an ampere rating equal to the ampere rating of the emergency circuit.

Figure 1.6 – Emergency Circuit Isolation Method

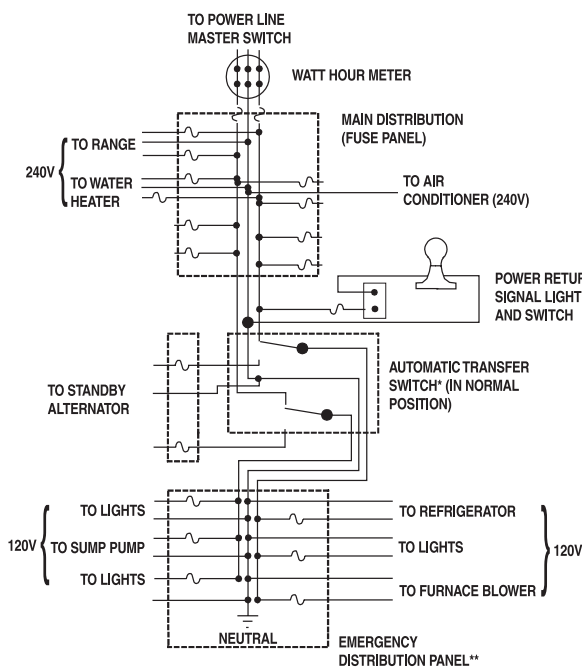

* Ampere rating must equal or exceed the ampere rating of the emergency distribution system.

** Ampere capacity is not to exceed the alternator rating. Only these items will be powered by the standby alternator. If the electrician sizes the load properly, the alternator cannot be overloaded.

All wiring must conform to the National Electrical Code, and all state and local codes. Consult a qualified, licensed electrician.

The above illustration assumes the utility is supplying 120/240-volt, single-phase electrical service.

1.9 TOTAL CIRCUIT ISOLATION METHOD

If essential electrical loads cannot be grouped together and wired into an emergency distribution panel, you will have to select load circuits that the generator will power during a utility power outage.

Be careful to avoid overloading the generator. The following apply to the “Total Circuit Isolation Method” (Figure 1.7):

- The transfer switch is installed between the utility service entrance and the distribution panel.
- The transfer switch ampere rating must be equal to the main electrical service entrance rating.

Figure 1.7 – Total Circuit Isolation Method

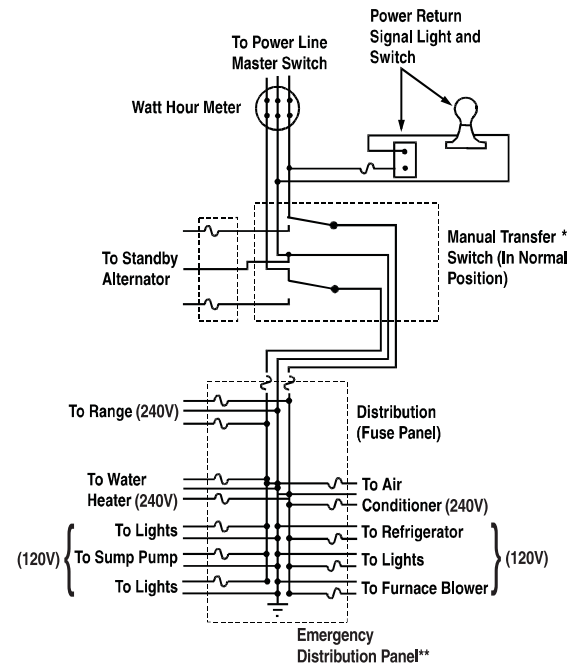

* Ampere rating is equal to or larger than main (normal) power source.

** Use caution with this system to prevent overload of the alternator during utility power failure. All load items in the distribution panel must be individually turned off. Only certain items can be turned back on during alternator operation. These items should be specified by your electrician so as not to overload the alternator.

All wiring must conform to the National Electrical Code, and all state and local codes. Consult a qualified, licensed electrician.

The above illustration assumes the utility is supplying 120/240-volt, single-phase electrical service.

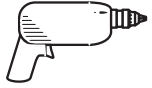

1.10 GENERATOR AC CONNECTION SYSTEM

Figure 1.8 represents a single-phase, three-wire generator AC connection system. The stator assembly in this system consists of a pair of stationary windings with two leads brought out of each winding. Each single winding can supply a 120-volt, 60-Hertz AC output. When the two windings are connected in series, a 240-volt, 60-Hertz AC output results. Stator AC output leads 11 and 44 are the two “hot” leads; the junction of leads 22 and 33 forms the neutral lead.

Figure 1.8 – Generator AC Connection System

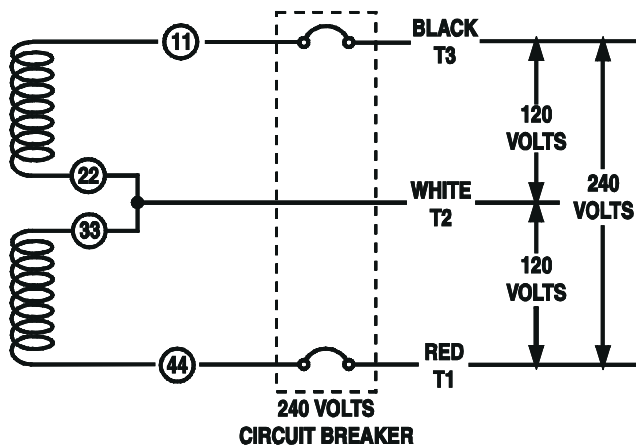

1.11 WIRING INTERCONNECTIONS



⚠ This generator uses an **UNGROUND**ED neutral line consisting of the junction of stator leads 22 and 33. Figure 1.9 and Figure 1.10 (page 13) are interconnection diagrams of home standby electrical systems. Power voltage leads and transfer switch “signal” leads must be run in separate conduit.

All wiring must be the proper size, properly supported, of approved insulative qualities, and protected by NEC approved conduit. Use a length of flexible conduit between the generator and any rigid conduit.

NOTE:

See also “Emergency Circuit Isolation Method,” section 1.8, and “Total Circuit Isolation Method,” section 1.9, on page 11.

◆ 1.11.1 6 KW, 8 KW AND 10 KW UNITS

Complete the following AC power lead connections for single-phase units (Figure 1.9, page 13):

1. Connect utility power supply leads to transfer switch terminals N1, N2 and the neutral lug.
2. Connect generator AC output leads from the generator’s main circuit breaker (CB1) and the generator neutral lug to transfer switch terminals E1, E2 and the neutral lug.
3. Connect circuit load leads to customer load, and to transfer switch terminals T1, T2 and the neutral lug.

◆ 1.11.2 SOUND ATTENUATED UNITS

The sound attenuated unit utilizes an internal 100-amp “V”-type transfer switch. The control and generator AC wires are prewired from the factory.

Complete the following AC power lead connections for single-phase units (Figure 1.10, page 13):

1. Connect utility power supply leads to transfer switch terminals N1, N2 and the neutral lug.
2. Connect circuit load leads to customer load, and to transfer switch terminals T1, T2 and the neutral lug.



Figure 1.9 – Interconnection Diagram for Single-Phase Power System (6 kW, 8 kW and 10 kW)

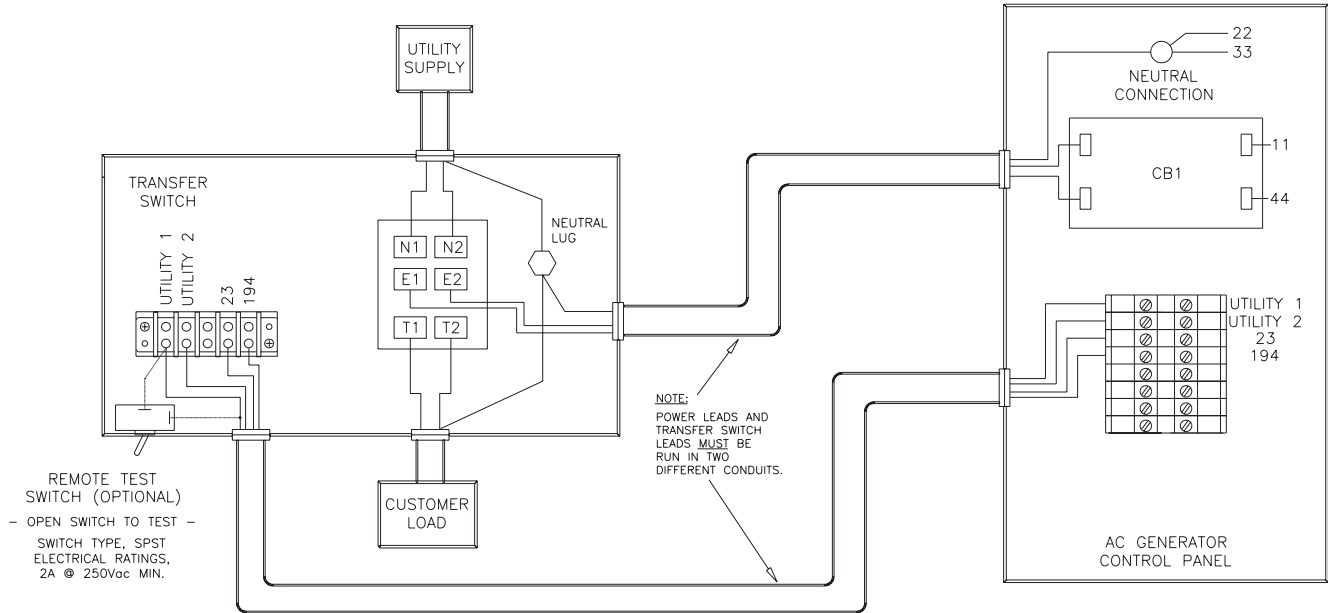

Figure 1.10 – Interconnection Diagram for Single-Phase Power System (Sound Attenuated)

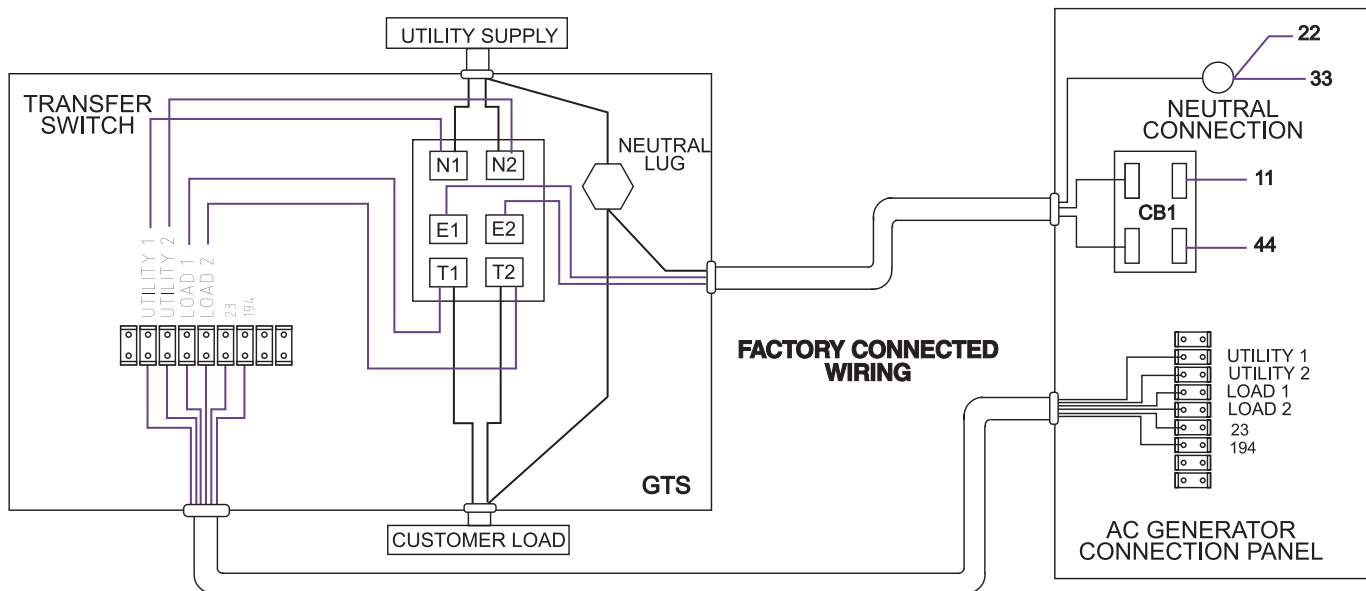
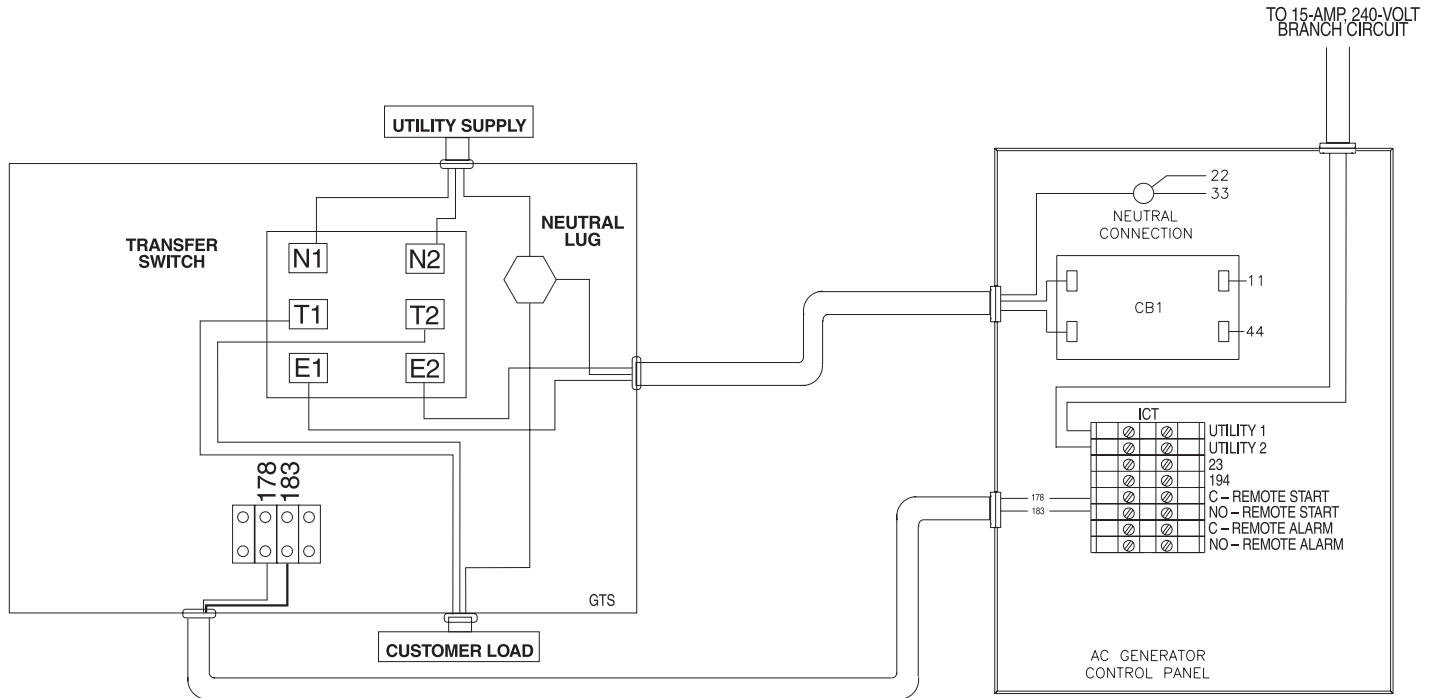



Figure 1.11 – Interconnection With GTS Transfer Switch (100A, y-type)



1.12 GENERATORS AND GTS TRANSFER SWITCHES

Guardian generators (this DOES NOT APPLY to single-phase sound attenuated units) may be installed with either a prepackaged transfer switch or with a standard GTS-type automatic transfer switch (Figure 1.11). You can do this by connecting generator control console terminals 178 and 183 to identically numbered terminals in the GTS switch. Turn dip switch #2 “Remote Not Auto” to the ON position on the generator control printed circuit board.

NOTE:

The enclosure roof will need to be removed to gain access to the printed circuit board.

When a Guardian generator is installed with a standard GTS-type switch, solid-state circuit boards in the transfer switch control automatic operation. For automatic operating sequences, parameters and timing, refer to the appropriate GTS transfer switch manual.

Automatic operation for Guardian generators installed with prepackaged transfer switches is controlled by a control module circuit board in the control panel. Refer to the “Operation” section of this manual.

1.13 CONTROL CIRCUIT INTERCONNECTIONS

For 6 kw, 8 kW and 10 kW units (not including sound attenuated), these interconnections consist of “Utility” and leads 23 and 194 (see Figure 1.9, page 13). These four leads must be routed in conduit that is separate from the generator AC power leads. Control lead functions may be briefly described as follows:

1. Utility 1 and Utility 2: Deliver utility source power to the generator's logic circuit board.
2. Leads 23 and 194: After the generator starts, the logic circuit board in control panel delivers a “transfer” signal via these two leads.
 - When logic circuit board action closes this circuit, it causes transfer switch main contacts to activate and connect load circuits to generator output.
 - When utility source voltage is restored, logic board opens leads 23 and 194 circuit. Loads are then transferred back to utility circuit.

NOTE:

Recommended size of control circuit leads (Utility 1 and 2, and 23 and 194) is No. 14 AWG stranded copper wire.



1.14 ADAPTING THREE-PHASE TRANSFER SWITCH

The generator you are installing may include a prepackaged transfer switch configured for three-phase loads. If you want to adapt this kind of transfer switch for single-phase loads, proceed as follows:

1. Discard the three-phase power monitor (PM) found inside the enclosure. You will not use it with a single-phase system.
2. Locate the eight-pin octal relay socket in the lower left corner of the transfer switch enclosure.
3. Move Wire N1A from Terminal 8 to Terminal 1 by cutting the lug off of N1A, stripping wire 5/16" from end, and inserting the wire under screw of Terminal 1.

NOTE:

Moving N1A from Terminal 8 to Terminal 1 takes the three-phase voltage monitor out of the sensing circuit. Now, the control circuit board in the control module assembly (CMA) senses utility voltage.

4. Now, connect the control wires as follows:
 - Connect Utility Supply to lugs N1 and N2.
 - Connect the Customer Load lugs T1 and T2.
 - Connect the Standby Supply to lugs E1 and E2.

1.15 CONTROL BOARD CONFIGURATION

The control board for the 6 kW, 8 kW and 10 kW has four dip switches (see Figure 1.12), which may be set up differently during installation.

1. Dip switch 1: When in the ON position, the board requires 20 Vac from the step down transformer to the control board to determine if utility is present. This switch is factory preset and should not need to be changed. This switch should be set in the OFF position.
2. Dip switch 2: When in the ON position, it will disable the automatic starting of these units. This should be set when utility is not present at the installation location. This is the only switch that may need to be set to the ON position for these models.
3. Dip switch 3: It will allow for 50 Hertz operation and is not applicable to these models. This switch is factory preset and should not need to be changed. This switch should be set in the OFF position.
4. Dip switch 4: It has no function at this time.

Figure 1.12 – Control Board Configuration

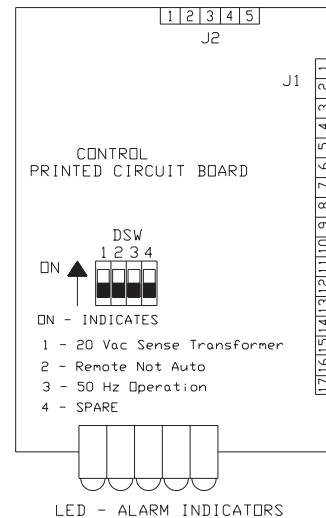

1.16 GROUNDING THE GENERATOR

Generally, connecting a No. 12 AWG stranded copper wire to the grounding lug (Figure 1.13) and to an earth-driven copper or brass grounding rod (electrode) will adequately ground the generator. However, local codes may vary widely. Consult with a local electrician for grounding requirements in your area.

Figure 1.13 – Grounding the Generator

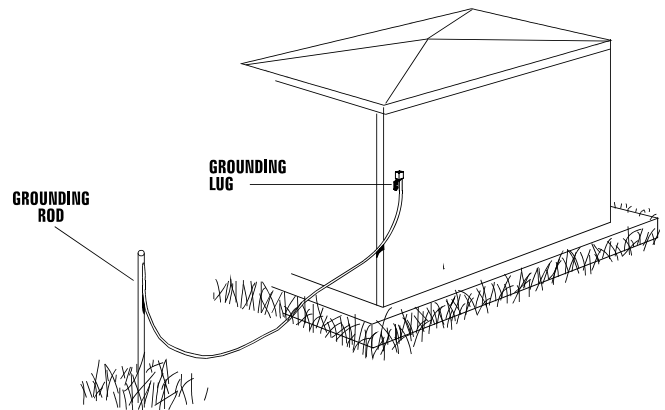

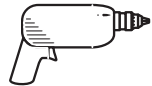

1.17 THE BATTERY

Servicing of the battery is to be performed or supervised by personnel knowledgeable of batteries and the required precautions. Keep unauthorized personnel away from batteries.

When replacing the battery, use the following type of battery: Group 26/26R 12-volt battery with a rating of 350 cold-cranking amps at -17.8° C (0° F) minimum. When using a maintenance-free battery, it is not necessary to check the specific gravity or electrolyte level. Have these procedures performed at the intervals specified in the *Owner's Manual* "Service Schedule." A negative ground system is used. Battery connections are shown on the wiring diagrams. Make sure the battery is correctly connected and terminals are tight. Observe battery polarity when connecting the battery to the generator set.

NOTE:

Damage will result if the battery connections are made in reverse.

Your generator is equipped with a battery trickle charger that is active when your unit is set up for automatic operation. The trickle charger is designed to help extend the life of your battery by maintaining the battery when the unit is not running.

⚠ DANGER ⚠

⚠ Do not dispose of the battery in a fire. The battery is capable of exploding.

⚠ A battery presents a risk of electrical shock and high short circuit current. The following precautions are to be observed when working on batteries:

- Remove watches, rings or other metal objects;
- Use tools with insulated handles;
- Wear rubber gloves and boots;
- Do not lay tools or metal parts on top of the battery; and
- Disconnect charging source prior to connecting or disconnecting battery terminals.

⚠ WARNING ⚠

⚠ Do not open or mutilate the battery. Released electrolyte has been known to be harmful to the skin and eyes, and to be toxic.

⚠ The electrolyte is a dilute sulfuric acid that is harmful to the skin and eyes. It is electrically conductive and corrosive. The following procedures are to be observed:

- Wear full eye protection and protective clothing;
- Where electrolyte contacts the skin, wash it off immediately with water;
- Where electrolyte contacts the eyes, flush thoroughly and immediately with water and seek medical attention; and
- Spilled electrolyte is to be washed down with an acid neutralizing agent. A common practice is to use a solution of 1 pound (500 grams) bicarbonate of soda to 1 gallon (4 liters) or water. The bicarbonate of soda solution is to be added until the evidence of reaction (foaming) has ceased. The resulting liquid is to be flushed with water and the area dried.

⚠ Lead-acid batteries present a risk of fire because they generate hydrogen gas. The following procedures are to be followed:

- DO NOT SMOKE when near the battery;
 - DO NOT cause flame or spark in battery area; and
 - Discharge static electricity from your body before touching the battery by first touching a grounded metal surface.
- ⚠ Be sure the Auto/Off/Manual switch is set to the OFF position before connecting the battery cables. If the switch is set to AUTO or MANUAL, the generator can crank and start as soon as the battery cables are connected.
- ⚠ Be sure the utility power supply is turned off, or sparking may occur at the battery posts as you attach the cables and cause an explosion.

◆ 1.17.1 BATTERY INSTALLATION

Fill the battery with the proper electrolyte fluid if necessary and have the battery fully charged before installing it.

Before installing and connecting the battery, complete the following steps:

1. Set the generator's Auto/Off/Manual switch to OFF.
2. Turn off utility power supply to the transfer switch.

⚠ WARNING ⚠

⚠ If the Auto/Off/Manual switch is not set to its OFF position, the generator can crank and start as soon as the battery cables are connected. If the utility power supply is not turned off, sparking can occur at the battery posts and cause an explosion.

Battery cables were factory connected at the generator (Figure 1.14). Connect cables to battery posts as follows:

1. Connect the red battery cable (from starter contactor) to the battery post indicated by a positive, POS or (+).
2. Connect the black battery cable (from frame ground) to the battery post indicated by a negative, NEG or (—).

Figure 1.14 – Battery Cable Connections

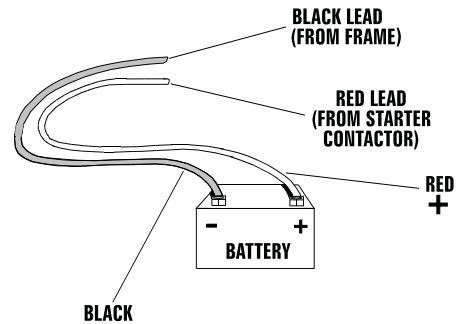

NOTE:

With the battery installed and utility power source voltage available to the transfer switch, the battery receives a trickle charge while the engine is not running, to prevent self-discharge. The trickle charge feature cannot be used to recharge a discharged battery.

1.18 THE FUSE

The generator panel's 15-amp fuse protects the DC control circuit against overload. The fuse is wired in series with the battery output lead to the panel. If the fuse element has melted open, you cannot crank or start the engine. You should replace the fuse using only an identical 15-amp replacement.

1.19 POST INSTALLATION INSPECTION

Before placing the home standby electrical system into service, inspect the entire installation carefully. Some areas may require that an inspection be performed by a building or electrical inspector.

Figure 1.15 – Typical Emergency Power System

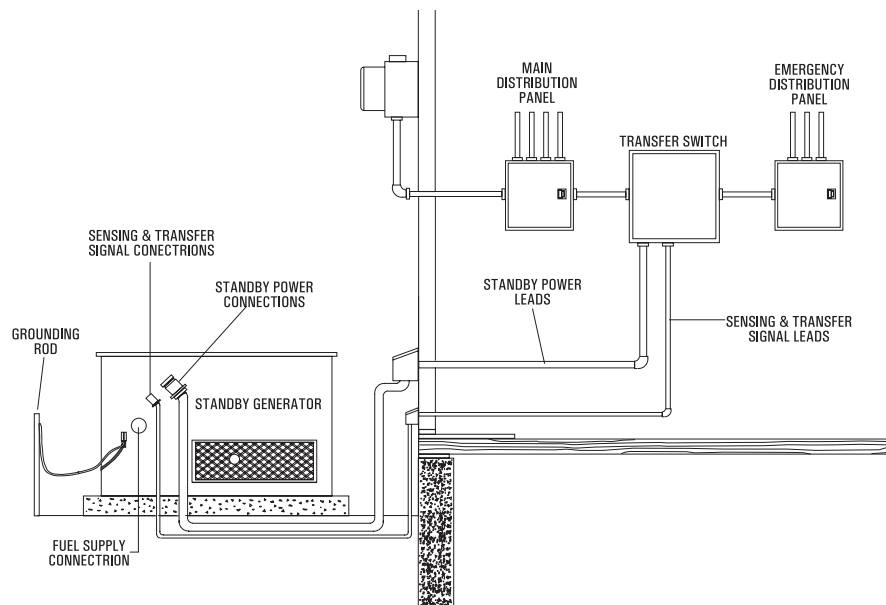

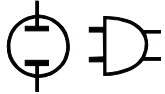

NOTE:

Throughout the “Operation” section, differences in procedures specific to sound attenuated units will be denoted as follows: (SA = information).

2.1 USING THE AUTO/OFF/MANUAL SWITCH (FIGURE 2.1/2.2)

◆ 2.1.1 “AUTO” POSITION

Selecting this switch position activates fully automatic system operation. It also allows you to start and exercise the engine every 14 (SA = seven) days with the setting of the exercise timer (see section 3.9). This position also is used for remote starting, when it is set up.

◆ 2.1.2 “OFF” POSITION

This switch position shuts down the engine. This position also prevents automatic operation.

◆ 2.1.3 “MANUAL” POSITION

Set the switch to MANUAL to crank and start the engine. Transfer to standby power will not occur unless there is a utility failure.

⚠ WARNING ⚠

⚠ With the switch set to AUTO, the engine may crank and start at any time without warning. Such automatic starting normally occurs when utility power source voltage drops below a preset level or during the normal exercise cycle. To prevent possible injury that might be caused by such sudden starts, always set the switch to OFF and remove the fuse before working on or around the generator or transfer switch. Then, place a “Do Not Operate” tag on the generator panel and on the transfer switch.

Figure 2.1 – Generator Control Panel (6 kW, 8 kW, 10 kW)

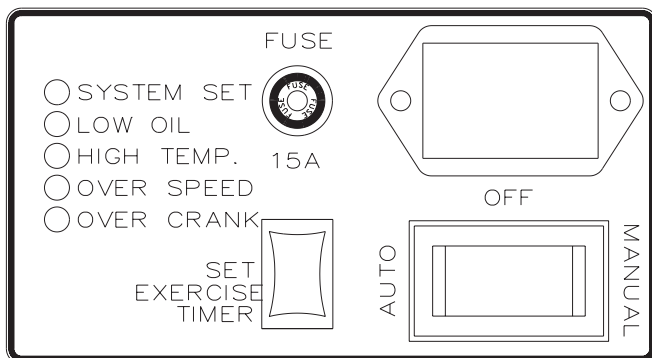
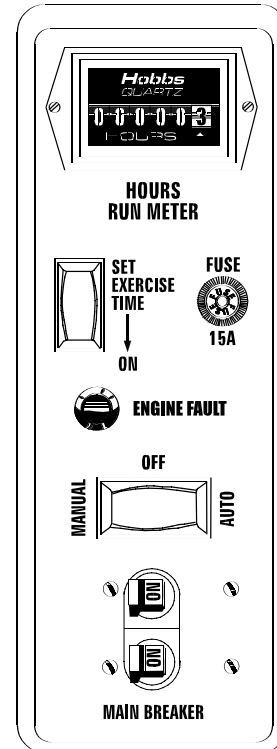

Figure 2.2 – Generator Control Panel (Sound Attenuated)



2.2 AUTOMATIC TRANSFER OPERATION

To select automatic operation, do the following:

1. Make sure the transfer switch main contacts are set to their “Utility” position, i.e., loads connected to the utility power source (Figure 2.3, page 19).
2. Be sure that normal utility power source voltage is available to transfer switch terminal lugs N1 and N2.
3. Set the generator’s Auto/Off/Manual switch to AUTO.
4. Set the generator’s main circuit breaker to its ON (or closed) position.

With the preceding steps complete, the generator will start automatically when utility source voltage drops below a preset level. After the unit starts, loads are transferred to the standby power source. Refer to “Sequence of Automatic Operation.”

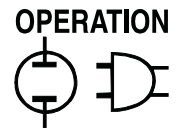

2.3 SEQUENCE OF AUTOMATIC OPERATION

The generator's control panel houses a control logic circuit board. This board constantly monitors utility power source voltage. Should that voltage drop below a preset level, circuit board action will signal the engine to crank and start. After the engine starts, the circuit board signals the transfer switch to activate and connect load circuits to the standby power supply (load terminal lugs T1/T2 connect to terminal lugs E1/E2).

Upon restoration of utility source voltage above a preset level, generator circuit board action signals the transfer switch to transfer loads back to that power supply. After retransfer, the engine is signalled to shut down.

The actual sequence of operation is controlled by sensors and timers on a control logic circuit board, as follows:

A. Utility Voltage Dropout Sensor

- This sensor monitors utility source voltage.
- If utility source voltage drops below about 60 percent of the nominal supply voltage, the sensor energizes a 15-second (SA = six-second) timer.
- Once the timer has expired, the engine will crank and start.

B. Engine Warm-up Time Delay

- This mechanism lets the engine warm up for about 10 (SA = 15) seconds before the load is transferred to a standby source.

C. Standby Voltage Sensor

- This sensor monitors generator AC output voltage. When the voltage has reached 50 percent of the nominal rated voltage, transfer to standby can occur.

D. Utility Voltage Pickup Sensor

- This sensor monitors utility power supply voltage. When that voltage is restored above 80 percent of the nominal source voltage, a retransfer time delay starts timing.

E. Retransfer Time Delay

- This timer runs for about 15 (SA = six) seconds.
- At end of a 15-second (SA = six-second) delay, circuit board action de-energizes transfer relay in the transfer switch.
- Retransfer to utility power source then occurs.

F. Engine Cool-down Timer

- When the load is transferred back to utility power source, the engine cool-down timer starts timing.
- The timer will run for about one minute, and the generator will then shut down.

NOTE:

Sound attenuated units have a control module assembly (CMA) board that reads frequency signals from the stator battery charge windings and relates them to engine speed or rpm. When AC frequency reaches about 30 Hertz, cranking is terminated and an engine warmup timer goes ON, running for approximately 15 seconds.

2.4 MANUAL TRANSFER OPERATION

◆ 2.4.1 TRANSFER TO GENERATOR POWER SOURCE

To start the generator and activate the transfer switch manually, proceed as follows:

1. Set the generator's Auto/Off/Manual switch to OFF.
2. Set the generator's main circuit breaker to its OFF (or open) position.
3. Turn OFF the utility power supply to the transfer switch using the means provided (such as a utility main line circuit breaker).



Do not attempt to activate the transfer switch manually until all power voltage supplies to the switch have been positively turned off. Failure to turn off all power voltage supplies may result in extremely hazardous and possibly fatal electrical shock.

Figure 2.3 – Manual Transfer Switch Operation

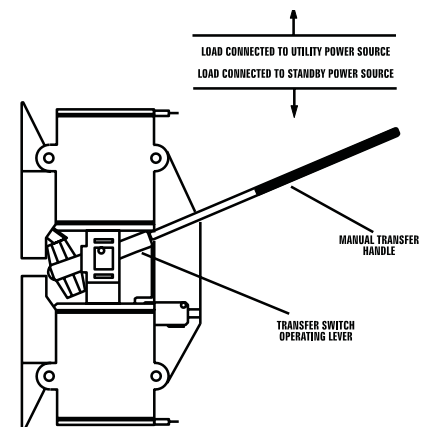

4. Use the manual transfer handle inside the transfer switch to move the main contacts to their "Standby" position, i.e., loads connected to the standby power source (Figure 2.3).
5. Turn ON the utility power supply to the transfer switch using the means provided (such as a utility main line circuit breaker).

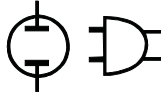

6. To crank and start the engine, set the Auto/Off/Manual switch to MANUAL.
7. Let the engine stabilize and warm up for a few minutes.
8. Set the generator's main circuit breaker to its ON (or closed) position. The standby power source now powers the loads.

◆ 2.4.2 TRANSFER BACK TO UTILITY POWER SOURCE

When utility power has been restored, you will want to transfer back to that source and shut down the generator. This can be accomplished as follows:

1. Set the generator's main circuit breaker to its OFF (or open) position.
2. Let the engine run for a minute or two at no-load to stabilize the internal temperatures.
3. Set the generator's Auto/Off/Manual switch to its OFF (or open) position. The engine should shut down.
4. Check that utility power supply to the transfer switch is turned OFF.



⚠ Do not attempt to activate the transfer switch manually until all power voltage supplies to the switch have been positively turned off. Failure to turn off all power voltage supplies may result in extremely hazardous and possibly fatal electrical shock.

5. Use the manual transfer handle inside the transfer switch to move the main contacts back to their "Utility" position, i.e., loads connected to the utility power source (Figure 2.3).
6. Turn ON the utility power supply to the transfer switch using the means provided.
7. Set the system to automatic operation as outlined in "Automatic Transfer Operation," section 2.2.

2.5 PROTECTION SYSTEMS

Unlike an automobile engine, the generator may have to run for long periods of time with no operator present to monitor engine conditions. For that reason, the engine is equipped with the following systems that protect it against potentially damaging conditions:

1. Low Oil Pressure Sensor
2. High Temperature Sensor
3. Overcrank
4. Overspeed

On sound attenuated models, there are LED read-outs on the control panel to notify you that one of these faults has occurred. There is also a "System Set" LED that is lit when all of the following conditions are true:

1. The Auto/Off/Manual switch is set to the AUTO position.
2. The "Not In Auto" dip switch is set to the OFF position on the control board.
3. No alarms are present.

◆ 2.5.1 LOW OIL PRESSURE SWITCH

This switch (Figure 2.4) has normally closed contacts that are held open by engine oil pressure during cranking and operating. Should oil pressure drop below the 8 psi range, switch contacts close, and the engine shuts down. The unit should not be restarted until oil is added, and the Auto/Off/Manual switch must be turned to OFF and then back to AUTO.

◆ 2.5.2 HIGH TEMPERATURE SWITCH

This switch's (Figure 2.4) contacts close if the temperature should exceed approximately 140° C (284° F), initiating an engine shutdown. Your generator will automatically restart and the LED will reset once the temperature has returned to a safe operating level.

Figure 2.4 – Low Oil Pressure and High Temperature Switches

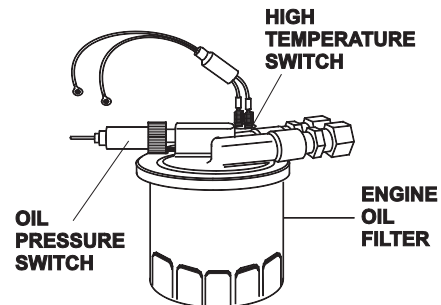

◆ 2.5.3 OVERCRANK

This feature prevents the generator from damaging itself when it continually attempts to start and another problem, such as no fuel supply, prevents it from starting. The unit will crank and rest for a preset time limit. Then, it will stop cranking, and the LED will light indicating an overcrank failure. The Auto/ Off/Manual switch will need to be set to OFF and then back to AUTO to reset the generator control board.

NOTE:

If the fault is not repaired, the overcrank feature will continue to activate.

2.5.3.1 Approximate Crank Cycle Times

- 15 seconds ON
- 15 seconds OFF
- 7 seconds ON
- 7 seconds OFF
- Repeat for 45 seconds
Approximately 90 seconds total

◆ 2.5.4 OVERSPEED

This feature protects the generator from damage by shutting it down if it happens to run faster than the pre-set limit. This protection also prevents the generator from supplying an output that could potentially damage appliances connected to the generator circuit. The over-speed feature will activate as follows:

1. If the generator runs at 72 Hertz for five seconds, the generator will shut down.
2. If the generator reaches 75 Hertz, it will shut down instantly.

2.6 ADDITIONAL GENERATOR FEATURES

◆ 2.6.1 6 KW, 8 KW AND 10 KW UNITS

The standard 6 kW, 8 kW and 10 kW air-cooled Guardians offer additional features that are not factory preset:

1. Remote Start – This allows for remote starting of the generator by means of the #183 (common) and #178 (normally open) lines with the Auto/Off/Manual switch set to AUTO. Closure of the circuit starts the unit; opening of the circuit stops the unit. See Figure 2.5.

NOTE:

This function will work ONLY with the unit in the AUTO mode.

Figure 2.5 – Remote Start/Alarm Options

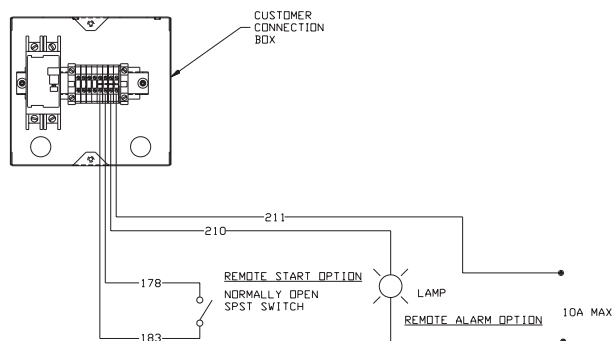

-Type 14 AWG wire is recommended.

-These options should be wired to the unit by a qualified electrician or Generac/Guardian Authorized Dealer.

2. Remote/Common Alarm – This allows for an alarm, light, horn, etc., to activate when any fault has occurred. Lines #210 (common) and #211 (normally open) provide a “closure” on common fault, which can be used for 120 volts, 10 amps maximum. See Figure 2.5.
3. Remote Not Auto – The generator will not automatically start during a utility failure.

◆ 2.6.2 SOUND ATTENUATED UNITS

Model 00844 of the sound attenuated air-cooled Guardians offers additional features that are not factory preset (see Figure 2.6):

1. Remote Start – This allows for remote starting of the generator by means of the #183 and #178 lines with the Auto/Off/Manual switch set to AUTO.
2. Engine Run Signal – The engine run signal is controlled by the #14 line. The “volt free” engine run signal relay closes when the #14 line is “hot.”
3. Automatic Transfer Switch (ATS) in Emergency – For this to be active, a microswitch on the transfer switch sends a signal along the #231 line to close the “volt free” contact relay.
4. Shutdown Fault – This signal is controlled by the main printed circuit board along the #229 line. When a common fault occurs (low oil pressure, high temperature, overspeed, overcrank), the control board will send a signal along the #229 line to close the “volt free” contact relay.

Figure 2.6 – Remote Alarms

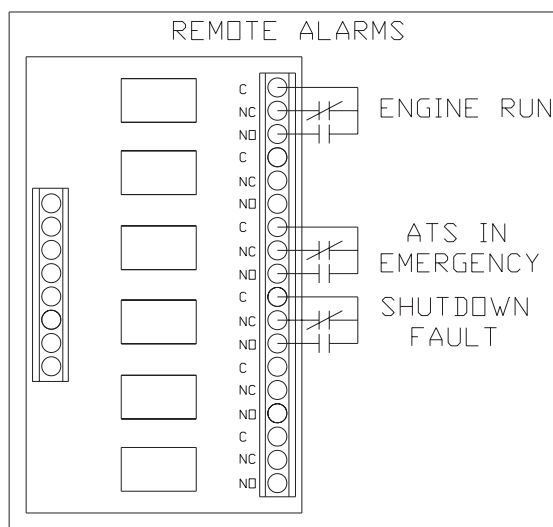

3.1 BEFORE INITIAL START-UP

Before starting, complete the following:

1. Set the generator's Auto/Off/Manual switch to the OFF position.
2. Turn OFF the utility power supply to the transfer switch using the means provided (such as the utility main line circuit breaker).
3. Check the engine crankcase oil level and, if necessary, fill to the dipstick FULL mark with the recommended oil. Do not fill above the FULL mark.
4. Check the fuel supply. Gaseous fuel lines must have been properly purged and leak tested in accordance with applicable fuel-gas codes. All fuel shutoff valves in the fuel supply lines must be open.

—  CAUTION  —

 Never operate the engine with the oil level below the "Add" mark on the dipstick. Doing this could damage the engine.

3.2 CHECK TRANSFER SWITCH OPERATION

Refer to section 2.4 (page 19) for manual operation procedures.

—  WARNING  —

 Do not attempt manual transfer switch operation until all power voltage supplies to the transfer switch have been positively turned off. Failure to turn off all power voltage supplies will result in extremely hazardous and possibly fatal electrical shock.

3.3 ELECTRICAL CHECKS

Complete electrical checks as follows:

1. Turn on the utility power supply to the transfer switch using the means provided (such as a utility main line circuit breaker).

—  DANGER  —

 The transfer switch is now electrically "hot." Contact with "hot" parts will result in extremely hazardous and possibly fatal electrical shock. Proceed with caution.

2. Use an accurate AC voltmeter to check utility power source voltage across terminals N1 and N2. Nominal line-to-line voltage should be 240 volts AC.
3. Check utility power source voltage across terminals N1 and the transfer switch neutral lug; then across terminal N2 and neutral. Nominal line-to-neutral voltage should be 120 volts AC.

4. When certain that utility supply voltage is compatible with transfer switch and load circuit ratings, turn OFF the utility power supply to the transfer switch.
5. Set the generator's main circuit breaker to its OFF (or open) position. Initial tests will be conducted at no-load condition.
6. On the generator panel, set the Auto/Off/Manual switch to MANUAL. The engine should crank and start.
7. Let the engine warm up for about five minutes to allow internal temperatures to stabilize. Then, set the generator's main circuit breaker to its ON (or closed) position.

—  DANGER  —

 Proceed with caution! Generator power voltage is now supplied to the transfer switch. Contact with live transfer switch parts will result in dangerous and possibly fatal electrical shock.

8. Connect an accurate AC voltmeter and an AC frequency meter across transfer switch terminal lugs E1 and E2. Voltage should be 242-252 volts; frequency should read about 61-63 Hertz.
9. Connect the AC voltmeter test leads across terminal lug E1 and neutral; then across E2 and neutral. In both cases, voltage reading should be 121-126 volts AC.
10. Set the generator's main circuit breaker to its OFF (or open) position. Let the engine run at no-load for a few minutes to stabilize internal engine generator temperatures.
11. Set the generator's Auto/Off/Manual switch to OFF. The engine should shut down.

NOTE:

It is important that you DO NOT proceed until you are certain that generator AC voltage and frequency are correct and within the stated limits. Generally, if both AC frequency and voltage are high or low, the engine governor requires adjustment. If frequency is correct, but voltage is high or low, the generator's voltage regulator requires adjustment.

3.4 GENERATOR TESTS UNDER LOAD

To test the generator set with electrical loads applied, proceed as follows:

1. Set generator's main circuit breaker to its OFF (or open) position.
2. Set the generator's Auto/Off/Manual switch to OFF.
3. Turn OFF the utility power supply to the transfer switch, using the means provided (such as a utility main line circuit breaker).

⚠ WARNING ⚠

- ⚠** Do not attempt manual transfer switch operation until all power voltage supplies to the transfer switch have been positively turned off. Failure to turn off all power voltage supplies will result in extremely hazardous and possibly fatal electrical shock.
4. Manually set the transfer switch to the STANDBY position, i.e., load terminals connected to the generator's E1/E2 terminals. The transfer switch operating lever should be down.
 5. Set the generator's Auto/Off/Manual switch to MANUAL. The engine should crank and start immediately.
 6. Let the engine stabilize and warm up for a few minutes.
 7. Set the generator's main circuit breaker to its ON (or closed) position. Loads are now powered by the standby generator.
 8. Turn ON electrical loads. Apply an electrical load equal to the full rated wattage/ampere capacity of the installed generator.
 9. Connect an accurate AC frequency meter across terminal lugs E1 and E2. Voltage should be greater than 230 volts; frequency should be greater than 58 Hertz.
 10. Let the generator run at full rated load for 20-30 minutes. Listen for unusual noises, vibration or other indications of abnormal operation. Check for oil leaks, evidence of overheating, etc.
 11. When testing under load is complete, turn OFF electrical loads.
 12. Set the generator's main circuit breakers to their OFF (or open) positions.
 13. Let the engine run at no-load for a few minutes.
 14. Set the Auto/Off/Manual switch to OFF. The engine should shut down.

3.5 CHECKING AUTOMATIC OPERATION

To check the system for proper automatic operation, proceed as follows:

1. Check that the Auto/Off/Manual switch is set to OFF.
2. Manually set the transfer switch to the UTILITY position, i.e., load terminals connected to the utility power source side.
3. Turn ON the utility power supply to the transfer switch, using the means provided (such as a utility main line circuit breaker).
4. Set the Auto/Off/Manual switch to AUTO. The system is now ready for automatic operation.
5. Turn OFF the utility power supply to the transfer switch.

With the Auto/Off/Manual switch at AUTO, the engine should crank and start when the utility source power is turned OFF. After starting, the transfer switch should connect load circuits to the standby side. Let the system go through its entire automatic sequence of operation.

With the generator running and loads powered by generator AC output, turn ON the utility power supply to the transfer switch. The following should occur:

- After about six seconds, the switch should transfer loads back to the utility power source.
- About one minute after retransfer, the engine should shut down.

3.6 ADJUSTING THE LOAD BLOCK

When the natural gas system is being used, the load block is fitted with an adjustment screw that has been calibrated to provide maximum power. However, because of variations in the Btu content of natural gas across the country, it may be necessary to readjust the load block.

- Connect a frequency meter to the output of the generator.
- Start the unit and apply full load according to the following chart:

Unit	120 Volts	240 Volts
6 kW:	50 amps	25 amps
8 kW:	66.7 amps	33.3 amps
10 kW:	83.3 amps	41.6 amps
Sound Attn.:	66.7 amps	33.3 amps

- Allow the unit to stabilize; then, turn the adjustment screw slowly clockwise or counterclockwise and watch the frequency.
- When the highest frequency is reached, turn the adjustment screw counterclockwise 1/4 turn.
- The fuel system is now set.
- For LP gas operations, the hose and blanking plug must be reconfigured as shown in Figure 1.3, page 7. The unit is set to provide maximum power using LP gas.

⚠ WARNING ⚠

- ⚠** Do not make any unnecessary adjustments. Factory settings are correct for most applications. However, when making adjustments, be careful to avoid overspeeding the engine.

3.7 ENGINE GOVERNOR ADJUSTMENT

If both AC frequency and voltage are correspondingly high or low, adjust the engine governor as follows:

◆ 3.7.1 6 KW UNITS

1. Loosen the governor clamp bolt (Figure 3.1).
2. Push the spring end of the governor lever clockwise to the wide open throttle position of the lever.
 - Hold the governor lever at wide open throttle and, with a pair of pliers, rotate the governor shaft fully clockwise.
 - While holding the governor shaft fully clockwise and the governor lever at wide open throttle, tighten the governor clamp bolt to 70 inch-pounds (8 N-m).
3. Start the engine; let it stabilize and warm up at no-load.
4. Turn the adjuster nut to obtain a frequency reading of 62 Hertz.
5. Determine if the governor spring is properly located in the slot of the governor lever as follows:
 - If droop is excessive, move the governor spring down one slot on the lever.
 - For greater stability, move the governor spring up one slot on the lever.
6. After repositioning the spring on a lever slot, recheck the frequency reading and, if necessary, readjust the adjuster nut to obtain 62 Hertz at no-load.
7. When frequency is correct at no-load, check the AC voltage reading. If voltage is incorrect, the voltage regulator may require adjustment.

*Figure 3.1 – 6 kW
Engine Governor Adjustment*

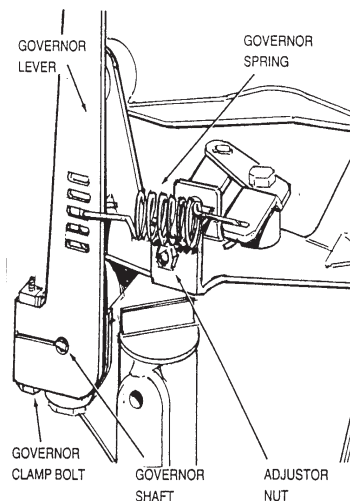

◆ 3.7.2 8 KW AND 10 KW UNITS

1. Loosen the governor clamp bolt (Figure 3.2).
2. Push the spring end of the governor lever clockwise to the wide open throttle position of the lever.
 - Hold the governor lever at wide open throttle and, with a screwdriver, rotate the governor shaft fully clockwise.
 - Before tightening, verify that the governor lever is pushed all the way onto the governor shaft.
 - While holding the governor shaft fully clockwise and the governor lever at wide open throttle, tighten the governor clamp bolt to 70 inch-pounds (8 N-m).
3. Start the engine; let it stabilize and warm up at no-load.
4. Turn the speed adjust nut to obtain a frequency reading of 62 Hertz.
5. When frequency is correct at no-load, check the AC voltage reading. If voltage is incorrect, the voltage regulator may require adjustment.

*Figure 3.2 – 8 kW and 10 kW
Engine Governor Adjustment*

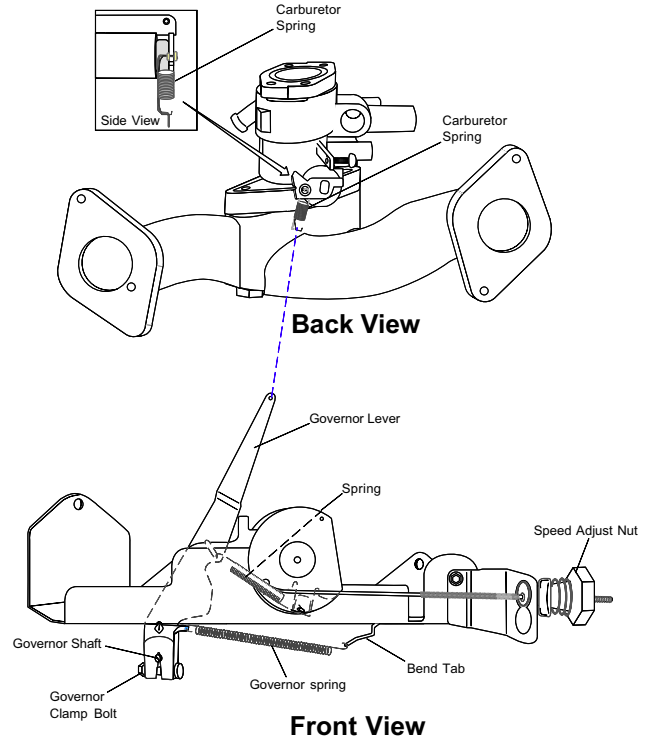

NOTE:

If the engine continues to run fast, use a pair of pliers to bend the bend tab clockwise to release tension on the lower governor spring.

◆ 3.7.3 SOUND ATTENUATED UNITS

1. Carefully inspect the governor anti-lash spring (Figure 3.3). Be sure it is not broken or disengaged.
2. Loosen the governor clamp nut. Then, push the spring end of the governor lever all the way up (wide open throttle).
3. Hold the governor lever at wide open throttle and insert the tip of a screwdriver into the slotted end of the governor shaft.
 - Hold the governor lever at wide open throttle and rotate the governor shaft fully counterclockwise.
 - Hold the governor shaft fully counterclockwise and tighten the governor clamp nut to 70 inch-pounds (8 N-m) torque.

Figure 3.3 – Sound Attenuated Engine Governor Adjustment

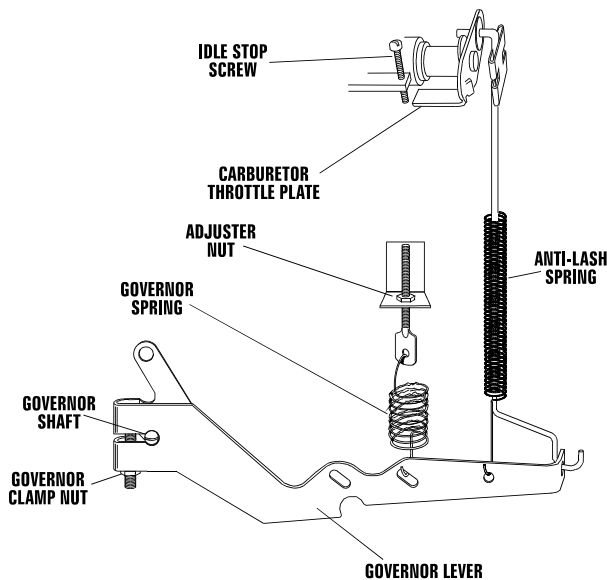

3.8 VOLTAGE REGULATOR ADJUSTMENT

With the frequency between 61-62 Hertz, slowly turn the slotted potentiometer (Figure 3.4) until line voltage reads 244-252 volts.

NOTE:

You must remove the roof to adjust the voltage regulator on nonsound attenuated units.

Figure 3.4 – Voltage Adjustment Potentiometer

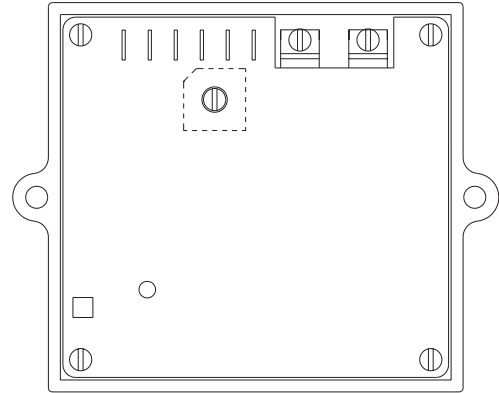

NOTE:

The voltage regulator is housed in the generator's control panel. The regulator maintains a voltage in direct proportion to frequency at a 2-to-1 ratio. For example, at 62 Hertz, line-to-neutral voltage will be 124 volts.

3.9 OVERSPEED ADJUSTMENT

◆ 3.9.1 6 KW, 8 KW AND 10 KW UNITS

See item 3 of section 1.15 on page 15 for overspeed adjustment information for these units.

◆ 3.9.2 SOUND ATTENUATED UNITS

Use the following overspeed adjustment procedure:

1. For initial setting, turn the potentiometer fully clockwise.*
2. Start the engine and increase the governed speed setting to 72 Hertz (62 Hertz for 50 Hertz rated units).

*NOTE:

If immediate shutdown occurs when the engine starts, reverse the potentiometer setting done in item 1.

3. Turn the adjustment potentiometer slowly until the engine shuts down.
4. Readjust the governor to the rated speed.

3.10 SETTING THE EXERCISE TIMER

◆ 3.10.1 6 KW, 8 KW AND 10 KW UNITS

Your generator is equipped with an exercise timer. Once it is set, the generator will start and exercise once every 14 days, on the day of the week and at the time of day you complete the following sequence. During this exercise period, the unit runs for approximately seven minutes and then shuts down. Transfer of loads to the generator output does not occur during the exercise cycle.

A switch on the control panel (see Figure 2.1, page 18) allows you to select the day and time for system exercise. To select the desired day and time of day, proceed as follows:

1. Verify that the Auto/Off/Manual switch is set to AUTO.
2. Hold down the Set Exercise Timer switch until the generator starts (approximately 10 seconds) and then release.
3. The generator will start and run for approximately seven minutes and then shut down on its own. The exerciser will then be set to run at that time of day every week.

NOTE:

The exerciser will only work in the AUTO mode and will not work unless this procedure is performed. The exerciser will need to be reset every time the 12-volt battery is disconnected and then reconnected. The exerciser WILL NOT work if dip switch 2 (Remote Not Auto) is ON.

◆ 3.10.2 SOUND ATTENUATED UNITS

The generator will start and exercise once every seven days. During this weekly exercise, the unit runs for about 20 minutes and shuts down. Transfer of loads to generator output does not occur during the exercise.

A switch on the control panel (see Figure 2.2, page 18) permits the day and time of day for system exercise to be selected. To select the desired day and time of day, proceed as follows:

1. Set the Auto/Off/Manual switch to OFF.
2. Set the generator's main circuit breaker to its OFF (or open) position.
3. On the control panel, locate the rocker switch identified with the words "Set Exercise Time."
4. Hold the "Set Exercise Time" switch in the ON (downward) position for 20 to 30 seconds. The switch springs back into its original position when released.
5. Wait about 30 seconds before setting the Auto/Off/Manual switch to AUTO.

—▲ CAUTION ▲—

- ▲ If you reset the Auto/Off/Manual switch too soon, the engine may start. If engine does start, it shuts off automatically in two minutes.
6. Set the generator's main circuit breaker to its ON (or closed) position. The generator will start and exercise every seven days thereafter, on the day and at the time of day you pressed the switch.



4.1 TROUBLESHOOTING GUIDE

PROBLEM	CAUSE	CORRECTION
The engine will not crank.	<ol style="list-style-type: none"> 1. Fuse blown 2. Loose, corroded or defective battery cables 3. Defective starter contactor 4. Defective starter motor 5. Dead battery 	<ol style="list-style-type: none"> 1. Replace fuse. 2. Tighten, clean or replace as necessary. 3. Replace starter contactor. 4. Replace starter motor. 5. Charge or replace battery.
The engine cranks but will not start.	<ol style="list-style-type: none"> 1. Out of fuel 2. Defective fuel solenoid (FS) 3. Open #14 wire from engine control board 4. Defective spark plug(s) 	<ol style="list-style-type: none"> 1. Replenish fuel. 2. Replace fuel solenoid. 3. Check connections and insulation of #14 wires. 4. Clean, re-gap or replace plug(s).
The engine starts hard and runs rough.	<ol style="list-style-type: none"> 1. Air cleaner plugged or damaged 2. Defective spark plug(s) 	<ol style="list-style-type: none"> 1. Check, clean or replace air cleaner. 2. Clean, re-gap or replace plug(s).
The engine starts but shuts down immediately.	<ol style="list-style-type: none"> 1. Engine oil level low 2. Defective low oil pressure switch 3. Defective high temperature switch 4. Defective control board 	<ol style="list-style-type: none"> 1. Check oil and add oil as needed. 2. Replace pressure switch. 3. Replace temperature switch. 4. Replace control board.
The Auto/Off/Manual switch is set to OFF, but the engine continues to run.	<ol style="list-style-type: none"> 1. Defective Auto/Off/Manual switch 2. Auto/Off/Manual switch wired incorrectly 3. Defective control board 	<ol style="list-style-type: none"> 1. Replace switch. 2. Check wiring and connections. 3. Replace control board.
There is no AC output from the generator.	<ol style="list-style-type: none"> 1. Main line circuit breaker open 2. Generator internal failure 	<ol style="list-style-type: none"> 1. Reset circuit breaker to ON (closed) position. 2. Contact an Authorized Dealer.
There is no transfer to standby after utility source failure.	<ol style="list-style-type: none"> 1. Defective transfer switch coil 2. Defective transfer relay 3. Transfer relay circuit open 4. Defective control logic board 	<ol style="list-style-type: none"> 1. Replace transfer switch coil. 2. Replace transfer relay. 3. Close transfer relay circuit. 4. Replace control logic board.
Unit starts automatically when switched to the AUTO position.	<ol style="list-style-type: none"> 1. Utility not present. 2. Defective Auto/Off/Manual switch 	<ol style="list-style-type: none"> 1. Switch dip switch 2 on control board if utility is not available. Check all connections if utility should be present. 2. Replace switch.
System Set LED is not lit when switched to the AUTO position.	<ol style="list-style-type: none"> 1. Failure present, i.e., low oil pressure 2. Dip switch 2 set to the ON position 	<ol style="list-style-type: none"> 1. Correct failure. 2. Switch to the OFF position if desired.



4.2 INSTALLATION CHECKLIST

◆ BATTERY INSTALLATION

- Battery is connected properly.
- Recommended battery is installed.
- Cables are clean and tight.
- Terminals are coated with anti-corrosion grease, and terminal covers are positioned.

◆ FUEL SYSTEM

- Complies with local and NFPA codes.
- Fuel is connected and checked for leaks.
- Correct fuel pressure (11-14 inches of water (0.6 psi) at all load ranges).
- Load block adjusted for maximum power for natural gas fuel.

◆ LOCATION

- Unit is fastened to concrete mounting pad.
- Louvers are free from obstruction.
- Exhaust is clear of flammable objects and debris.

◆ ELECTRICAL CONNECTIONS

- Complies with local code requirements and all National Electrical Codes.
- Utility is connected and present.
- Transfer switch is connected.
- All wires running outside of the generator are in NEC-approved conduit. *Note: Utility wires and transfer switch control wires must be in separate conduit.
- Unit is grounded to an approved earth ground.

◆ COOLING AND VENTILATING

- All inlets and outlets are free from obstruction. See Figure 1.4 and Figure 1.5.

◆ OTHER

- Verify that the unit is filled to the proper level with the proper break-in oil. Adjust as required.

◆ OPTIONS AND ACCESSORIES

- Control board is configured properly. See section 1.15.
- Remote alarm is installed if desired. See section 2.6.
- Remote start is installed if desired. See section 2.6.

Section 5 – Electrical Data

Guardian Air-cooled 6 kW, 8 kW and 10 kW (nonsound attenuated) Generators
Transfer Switch Schematic and Wiring Diagrams – Drawing No. C2381-



WIRING DIAGRAM

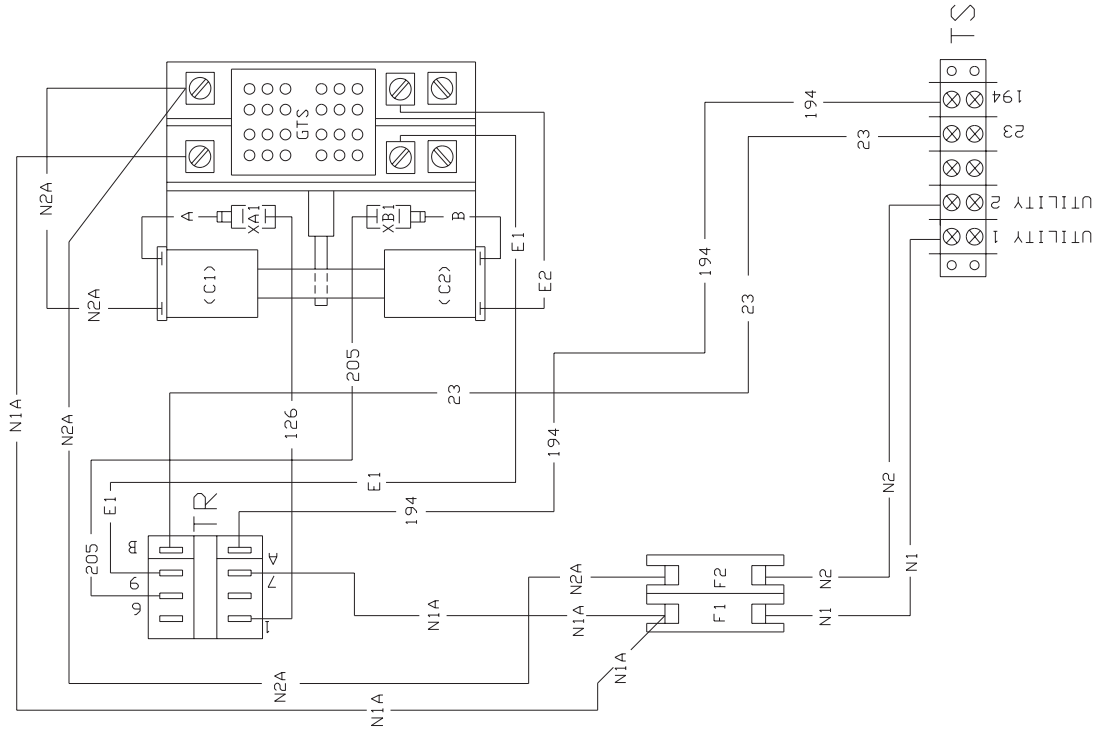

SCHEMATIC DIAGRAM

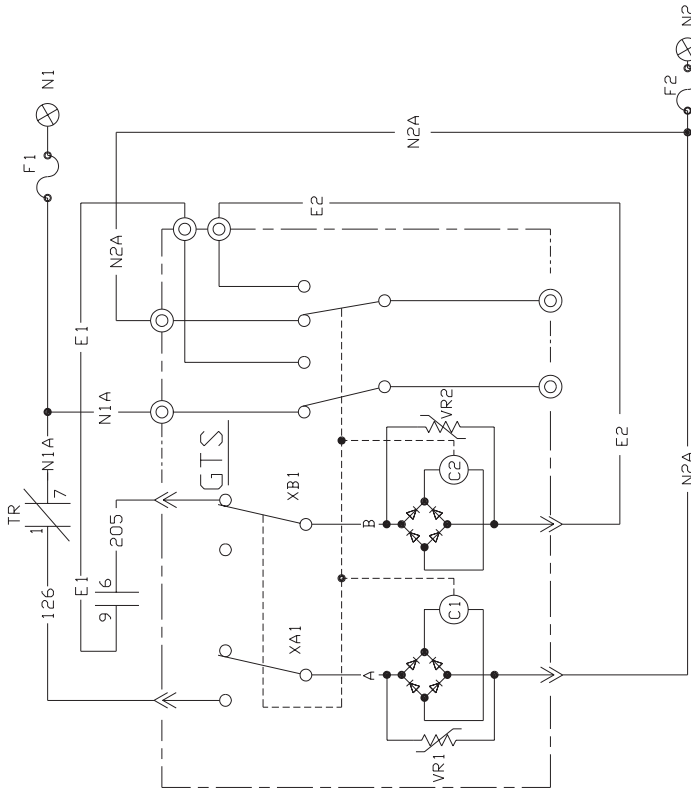

LEGEND	
C1-	SOLENOID COIL (UTILITY CLOSING)
C2-	SOLENOID COIL (STANDBY CLOSING)
GTS -	TRANSFER SWITCH CONTACTOR
TR -	RELAY, TRANSFER
TS -	TERMINAL STRIP (CUSTOMER CONNECTION)
XA1, XB1-	LIMIT SWITCHES, ACTUATOR
F1, F2 -	FUSE, 5A SENSING
VR1, VR2 -	VARIATOR

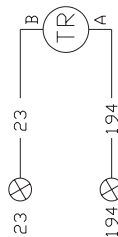

NOTE:
ALL CONTACTS SHOWN WITH
TRANSFER SWITCH IN UTILITY
POSITION.

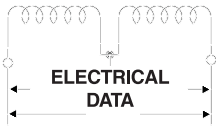

Section 5 – Electrical Data

Guardian Air-cooled 6 kW, 8 kW and 10 kW (nonsound attenuated) Generators Wiring Diagram – Drawing No. C2136-C

ENGINE WIRING

DIAGRAM KEY

- BA - BRUSH ASSEMBLY
- BCR - BATTERY CHARGE RECTIFIER
- CB1 - MAIN OUTPUT BREAKER
- CB2 - CIRCUIT BREAKER, ALTERNATOR EXCITATION
- D - DIODE
- DSW - PCB MOUNTED DIP SWITCH
- FS - FUEL SOLENOID
- F1 - FUSE 15 AMP
- GRD - CONTROL PANEL GROUND
- HTO - HIGH OIL TEMPERATURE SWITCH
- HM - HOUR RUN METER
- IC - INLINE CONNECTOR
- ICT - INTERCONNECTION TERMINALS
- IM1 - IGNITION MODULE, CYLINDER #1
- IM2 - IGNITION MODULE, CYLINDER #2
- LDP - LOW OIL PRESSURE SWITCH
- RAR - REMOTE ALARM RELAY
- R1 - 1 OHM, 25W RESISTOR
- SP1, SP2 - SPARK PLUGS
- SW1 - AUTO / OFF / MANUAL SWITCH
- SW2 - SET EXERCISE SWITCH
- SM - STARTER MOTOR
- SS - STARTER SOLENOID
- TB - INSULATED TERMINAL BLOCK
- TX1 - 56 VA TRANSFORMER - 240 / 16 Vac
- TX2 - 6 VA TRANSFORMER - 240 / 16 Vac

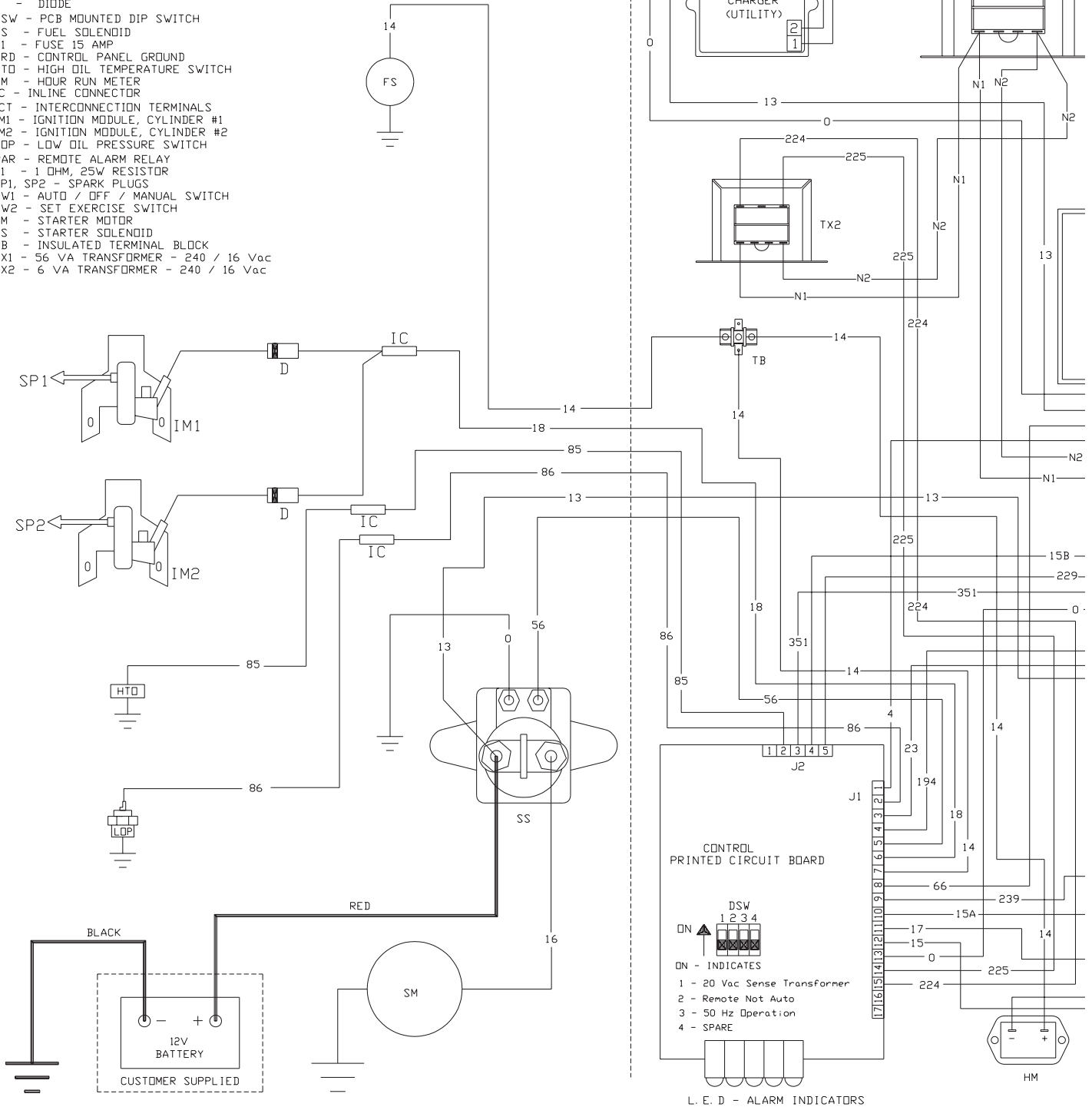

L. E. D - ALARM INDICATORS

Section 5 – Electrical Data

Guardian Air-cooled 6 kW, 8 kW and 10 kW (nonsound attenuated) Generators
Wiring Diagram – Drawing No. C2136-C

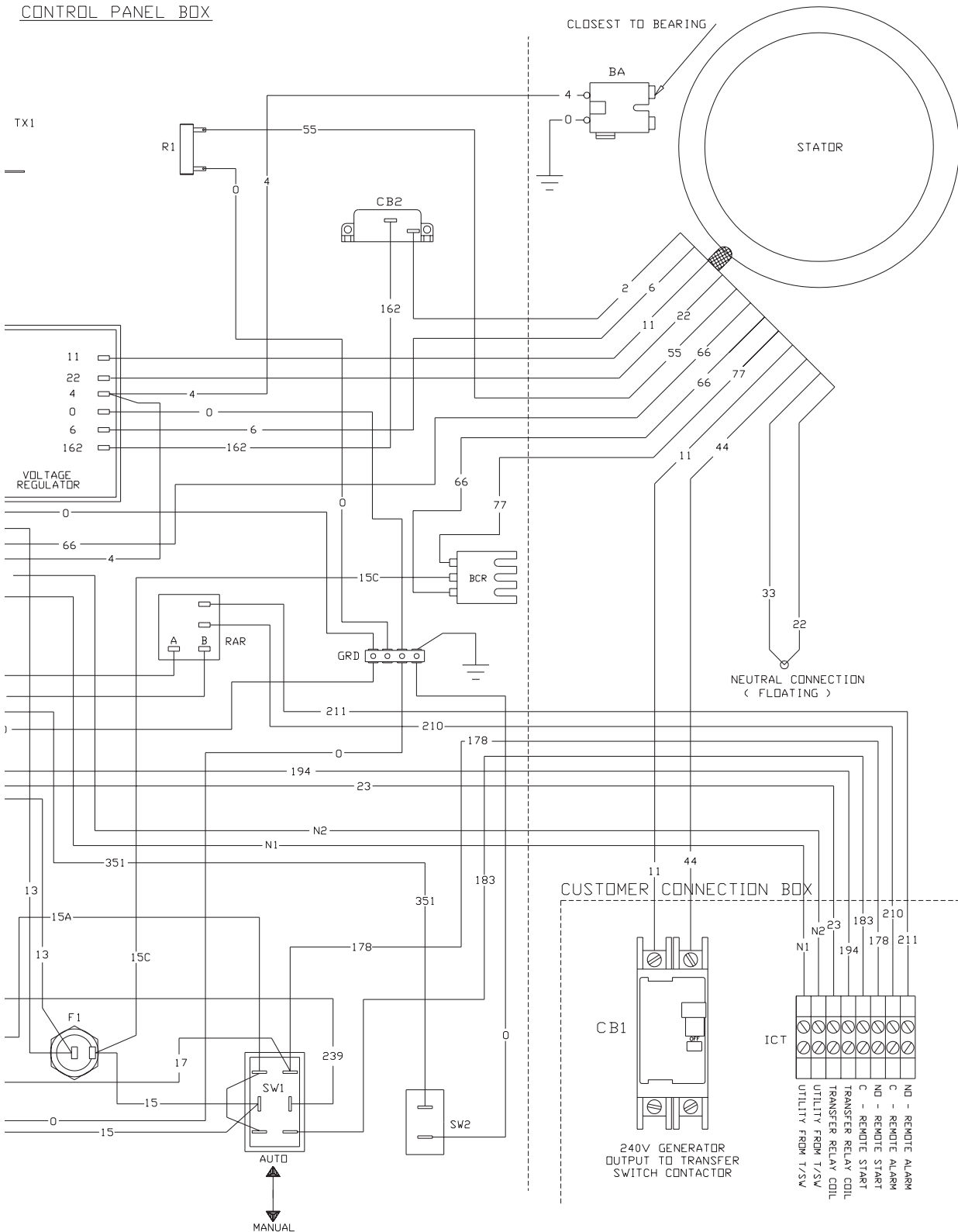
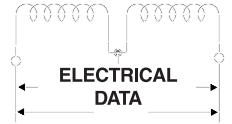

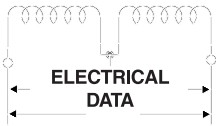

Section 5 – Electrical Data

Guardian Air-cooled 6 kW, 8 kW and 10 kW (nonsound attenuated) Generators Electrical Schematic – Drawing No. C2666-B

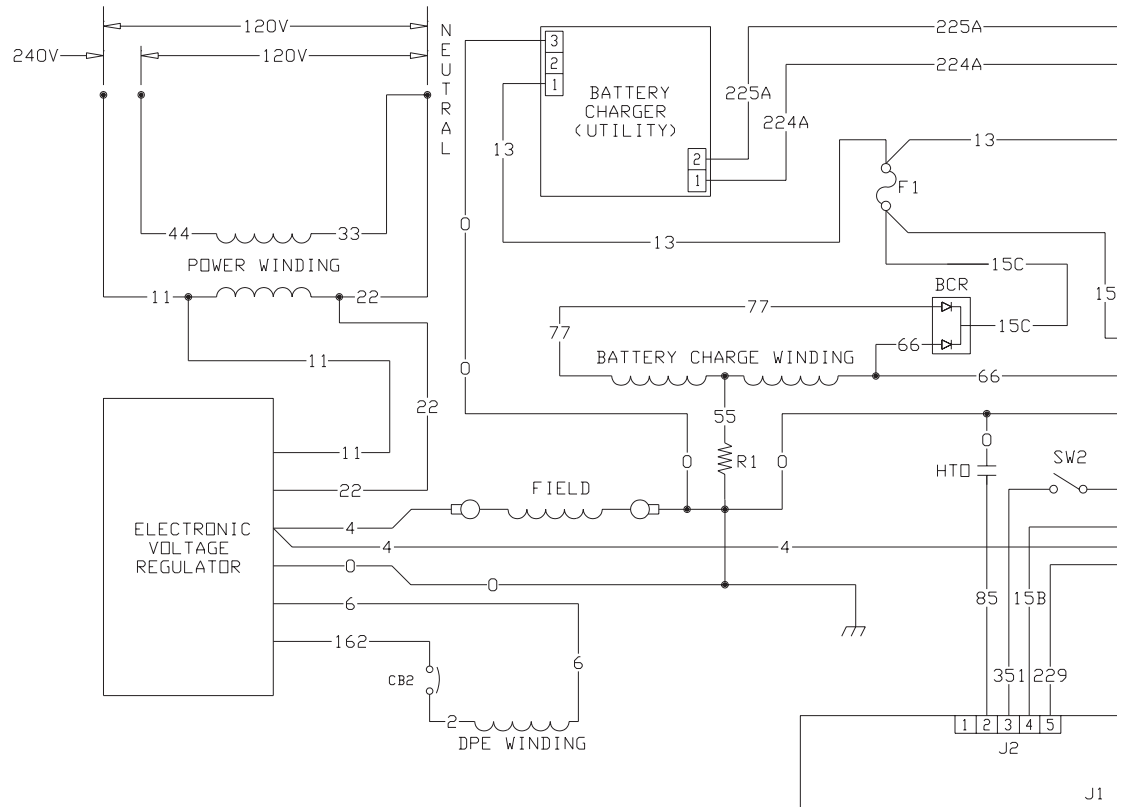

DIAGRAM KEY

- BCR – BATTERY CHARGE RECTIFIER
- CB2 – CIRCUIT BREAKER, ALTERNATOR EXCITATION
- FS – FUEL SOLENOID
- F1 – FUSE 15 AMP
- HTO – HIGH OIL TEMPERATURE SWITCH
- HM – HOUR RUN METER
- IM1 – IGNITION MODULE, CYLINDER #1
- IM2 – IGNITION MODULE, CYLINDER #2
- LOP – LOW OIL PRESSURE SWITCH
- RAR – REMOTE ALARM RELAY
- R1 – 1 OHM, 25W RESISTOR
- SC – STARTER CONTACTOR
- SP1, SP2 – SPARK PLUGS
- SW1 – AUTO / OFF / MANUAL SWITCH
- SW2 – SET EXERCISE SWITCH
- SM – STARTER MOTOR
- TX1 – 56 VA TRANSFORMER – 240 / 16 Vac
- TX2 – 6 VA TRANSFORMER – 240 / 16 Vac

CONTROL
PRINTED CIRCUIT
BOARD

Section 5 – Electrical Data

Guardian Air-cooled 6 kW, 8 kW and 10 kW (nonsound attenuated) Generators
Electrical Schematic – Drawing No. C2666-B

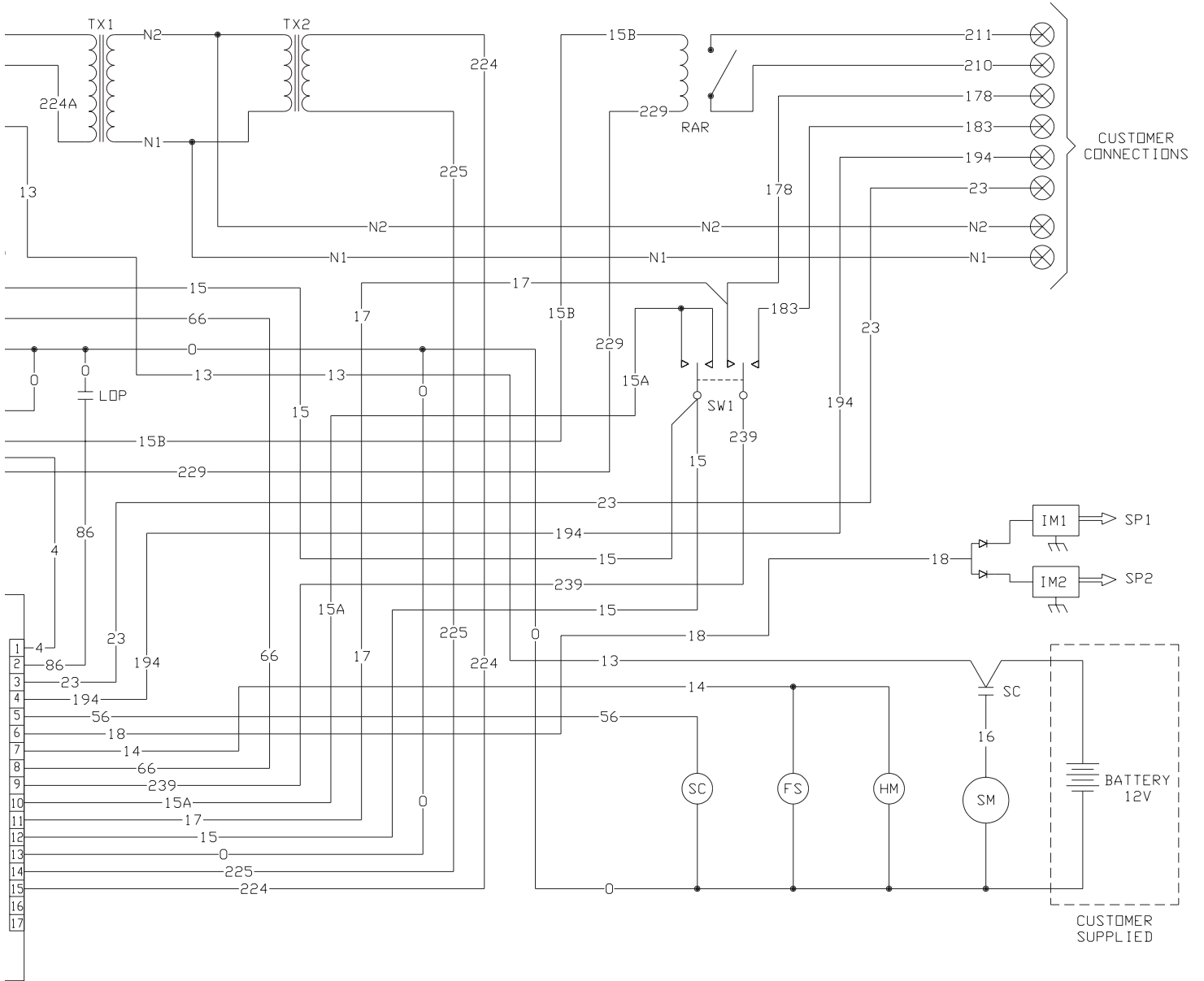
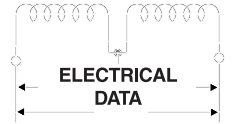

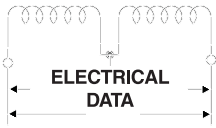

Section 5 – Electrical Data

Guardian Air-cooled Sound Attenuated Generator Model 00789 Wiring Diagram – Drawing No. A2607-A

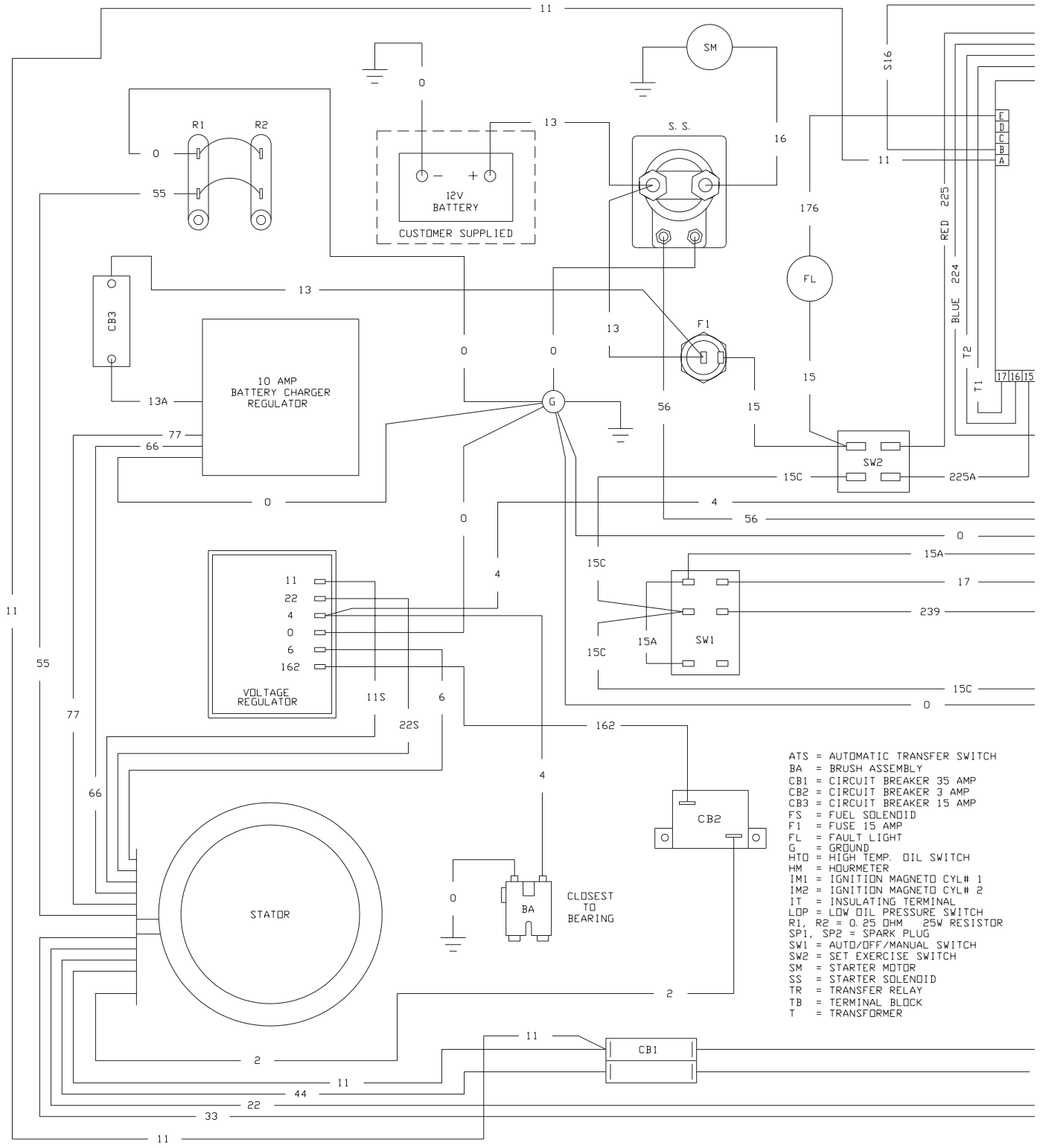

Section 5 – Electrical Data

Guardian Air-cooled Sound Attenuated Generator Model 00789
Wiring Diagram – Drawing No. A2607-A

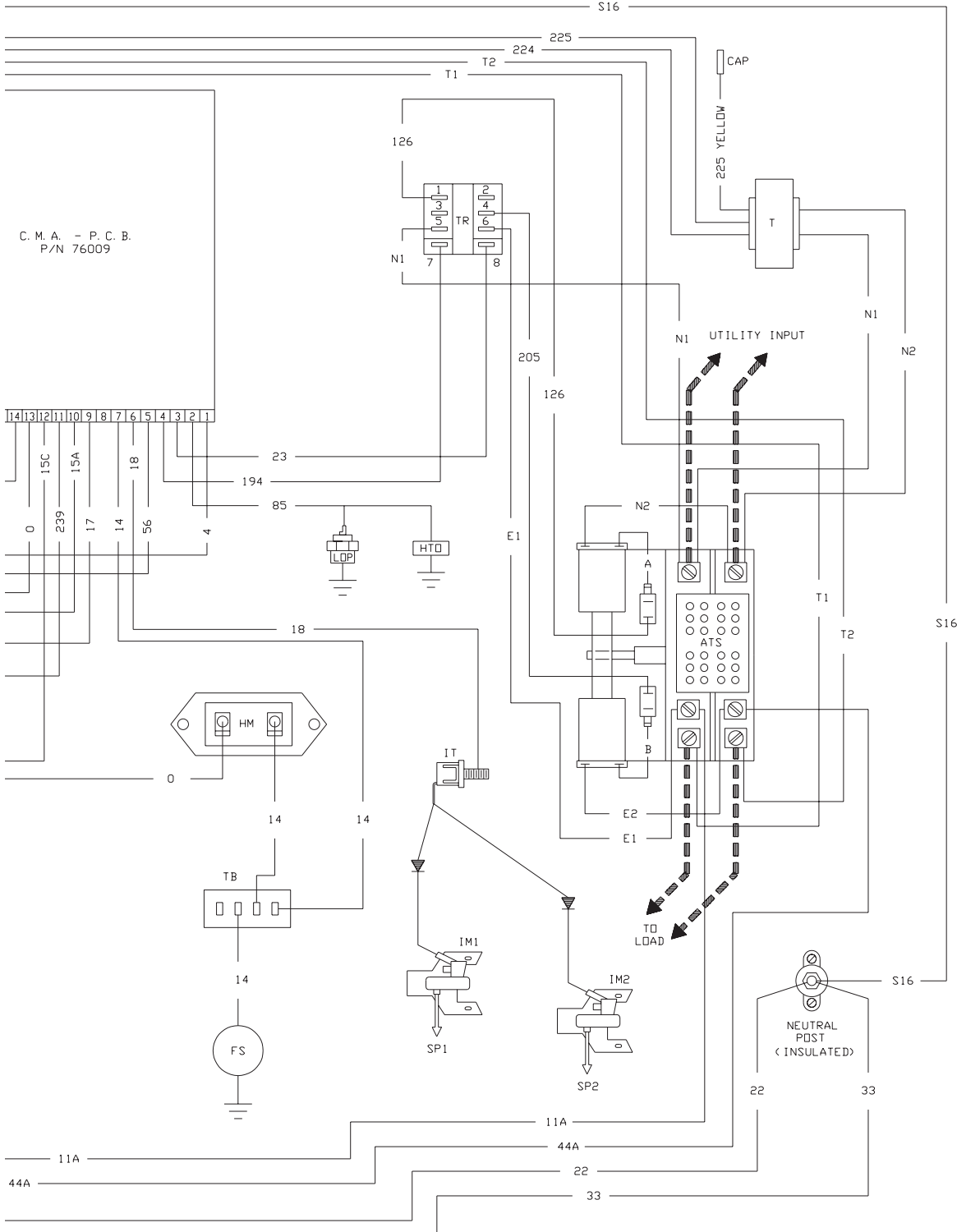
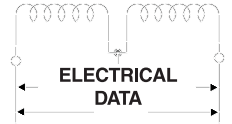

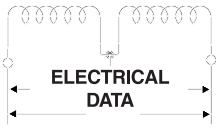

Section 5 – Electrical Data

Guardian Air-cooled Sound Attenuated Generator Model 00844 Wiring Diagram – Drawing No. A2787-B

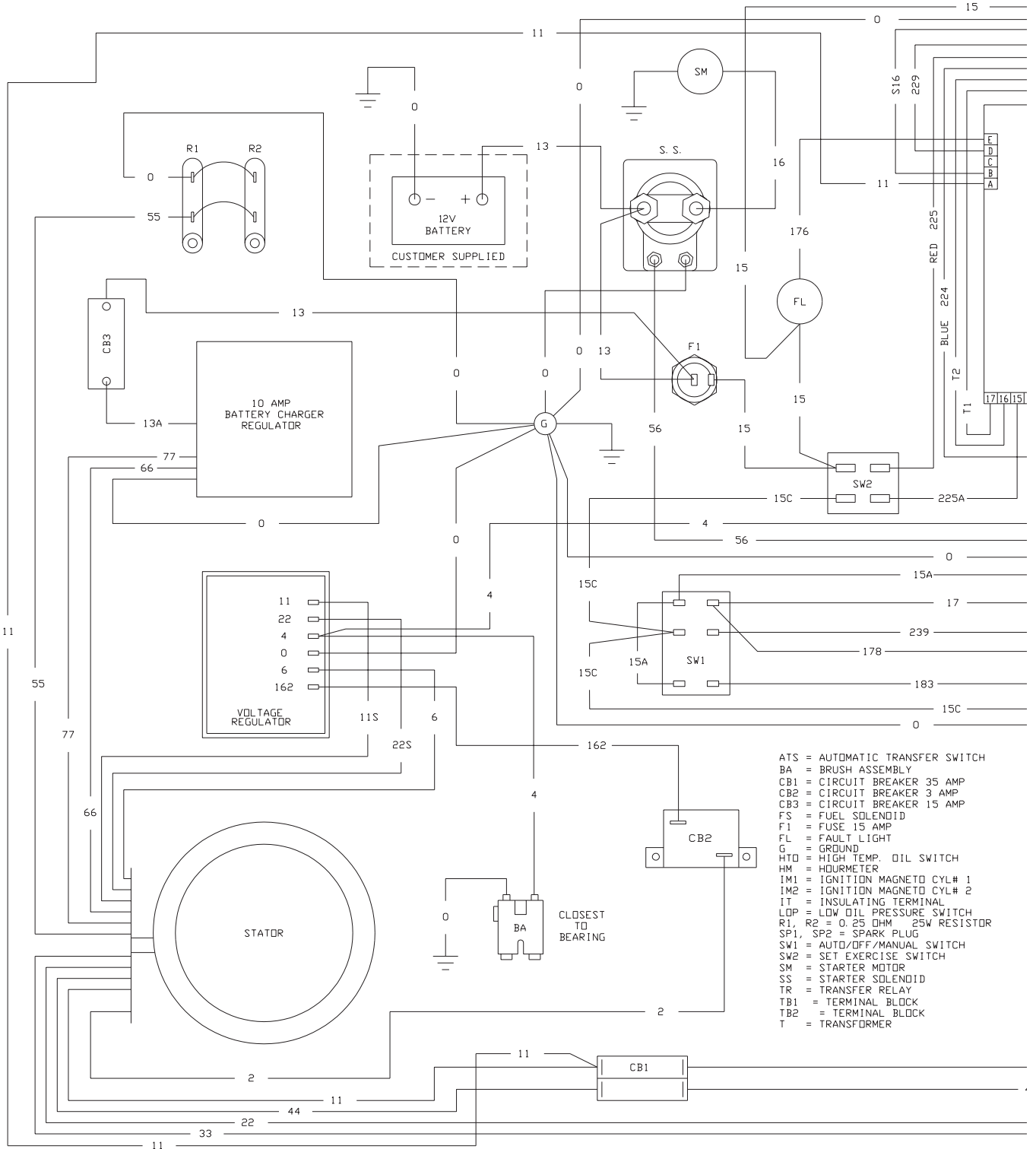

GENERAC® POWER SYSTEMS, INC.
P.O. BOX 8 • WAUKESHA, WI 53187
PH: (414) 544-4811 • FAX: (414) 544-5689

Part No. C2165

Revision A (08/31/99)

Printed in U.S.A.