

# OWNER'S MANUAL

## MOHAWK BRAVE 4, 5 & 6

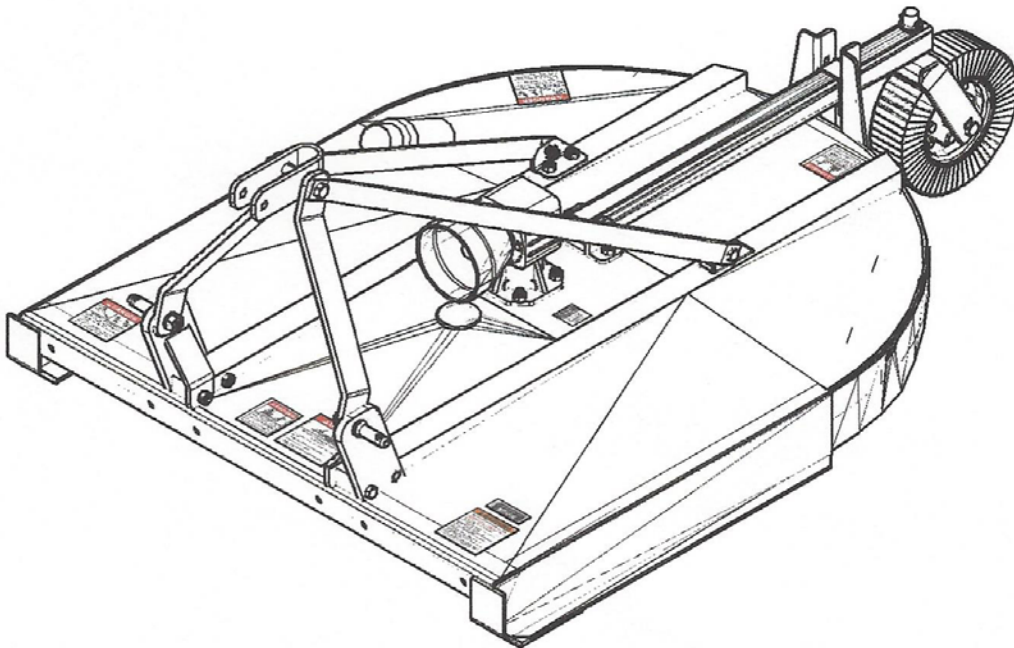

**AG-MEIER INDUSTRIES, LLC**  
**920 E. 6<sup>TH</sup> AVE. BELTON, TX 76513**  
**254-939-3731**  
**FAX 254-939-1351**  
**AG-MEIER.NET**

**DATE:03-03-2016**

## TABLE OF CONTENTS

INTRODUCTION .....	1
ASSISTANCE .....	1
SAFETY.....	2
SAFETY SIGNAL WORDS & SAFETY ALERT SYMBOL .....	2
GENERAL SAFETY GUIDELINES.....	3
SAFETY SIGN LOCATIONS.....	4
SAFETY DECAL CARE .....	6
LIGHTING AND MARKING .....	6
BEFORE OPERATION .....	7
DURING OPERATION.....	8
HIGHWAY AND TRANSPORT OPERATIONS .....	9
FOLLOWING OPERATION.....	10
PERFORMING MAINTENANCE .....	11
HYDRAULIC FLUID AND EQUIPMENT SAFETY .....	12
LOCKOUT/TAGOUT.....	12
OPERATIONS .....	16
MAINTENANCE .....	20
TROUBLE SHOOTING .....	23
PARTS.....	26
WARRANTY .....	37
BOLT TORQUE CHART .....	38
WARRANTY REGISTRATION FORM & INSPECTION REPORT .....	39

## **INTRODUCTION**

Thank you for purchasing a Mohawk Rotary Cutter. We hope you will get many years of productive use from it. This cutter is designed to be pulled by a ROPS protected tractor of proper size. This rotary cutter is designed to be used on pastures, fields, and road sides that are level to slightly sloping. All product users must read and understand this manual prior to equipment operation. This manual is considered part of your machine and should remain with the machine at all times. Do not allow anyone to operate or maintain this equipment that has not fully read and comprehended this manual. Failure to follow the recommended procedures may result in personal injury or death or equipment damage.

Information in this manual is designed to help owners and operators to obtain the best results and safe operation from their investment. The life of any machine depends largely on the care it is given and we suggest that the manual should be read and understood and referred to frequently. If for any reason you do not understand the instructions and safety requirements, please contact your authorized dealer. The intent of this manual is to provide guidelines to cover general use and to assist in avoiding accidents and injuries.

There may be times when circumstances occur that are not covered in the manual. At those times it is best to use common sense and contact your authorized dealer or our factory.

The requirements of safety cannot be emphasized enough in this publication. We urge you to make safety your top priority when using and maintaining the equipment. We strongly advise that anyone allowed to operate this equipment be thoroughly trained and tested, to prove they understand the fundamentals of safe operation.

Some photographs, diagrams or illustrations in this manual may show doors, guards and shields opened or removed to aid in clarity and understanding of a particular procedure. All guards, shields and safety devices must be in their proper position prior to operation.

## **ASSISTANCE**

If you have questions not answered in this manual, or require additional copies, or the manual is damaged, please contact your dealer or:

AG-MEIER IND. L.L.C.  
920 E. 6<sup>TH</sup> AVE.  
BELTON, TX 76513

E-mail address  
sales@agmeierindustries.com  
Phone 800 446 7319



## SAFETY

Read and understand this manual and all safety signs before operating and maintaining. Review the safety instructions and precautions annually.

**TAKE NOTE! THIS SAFETY ALERT SYMBOL FOUND THROUGHOUT THIS MANUAL IS USED TO CALL YOUR ATTENTION TO INSTRUCTIONS INVOLVING YOUR PERSONAL SAFETY AND THE SAFETY OF OTHERS. FAILURE TO FOLLOW THESE INSTRUCTIONS CAN RESULT IN INJURY OR DEATH.**



### THIS SYMBOL MEANS

- ATTENTION!
- BECOME ALERT!
- YOUR SAFETY IS INVOLVED!



## SAFETY SIGNAL WORDS

Note the use of the signal words DANGER, WARNING and CAUTION with the safety messages. The appropriate signal word for each has been selected using the following guidelines:



**DANGER:** Indicates an imminently hazardous situation that, if not avoided, will result in death or serious injury. This signal word is to be limited to the most extreme situations typically for machine components which, for functional purposes, cannot be guarded.



**WARNING:** Indicates a potentially hazardous situation that, if not avoided, could result in death or serious injury, and includes hazards that are exposed when guards are removed. It may also be used to alert against unsafe practices.



**CAUTION:** Indicates a potentially hazardous situation that, if not avoided, may result in minor or moderate injury. It may also be used to alert against unsafe practices.



## GENERAL SAFETY GUIDELINES

Safety of the operator and any bystanders is one of the main concerns in designing and developing a new piece of equipment. Designers and manufacturers build in as many safety features as possible. However, every year many accidents occur which could have been avoided by a few seconds of thought and a more careful approach to handling equipment. You, the operator, can avoid many accidents by observing the following precautions in this section. To avoid personal injury, study the following precautions and insist those working with you, or for you, follow them.

Replace any CAUTION, WARNING, DANGER or instruction safety decal that is not readable or is missing. Location of such decals is indicated in this booklet.

Do not attempt to operate this equipment under the influence of drugs or alcohol. Do not use the equipment if alertness or coordination is impaired.

Review the safety instructions with all users annually.

This equipment is dangerous to children and persons unfamiliar with its operation. The operator should be a responsible adult familiar with farm machinery and trained in this equipment's operations. **Do not allow persons to operate or assemble this unit until they have read this manual and have developed a thorough understanding of the safety precautions and of how it works.**

Do not read, eat, drink, talk or text or use a mobile phone while using this equipment.

To prevent injury or death, use a tractor equipped with a Roll Over Protective System (ROPS). Do not paint over, remove or deface any safety signs or warning decals on your equipment. Observe all safety signs and practice the instructions on them.

Never exceed the limits of a piece of machinery. If its ability to do a job, or to do so safely, is in question - **DON'T TRY IT.**

Stay clear of any moving parts, such as shafts, couplings and universal joints.

If adjustments need to be made, make them in small steps, shutting down all motions for each adjustment.

Do not allow anyone to ride on any part of the equipment for any reason.

Assure that all bystanders are at a safe distance before operating or maintaining this equipment.



## SAFETY SIGN LOCATIONS

Safety Sign location is shown below.

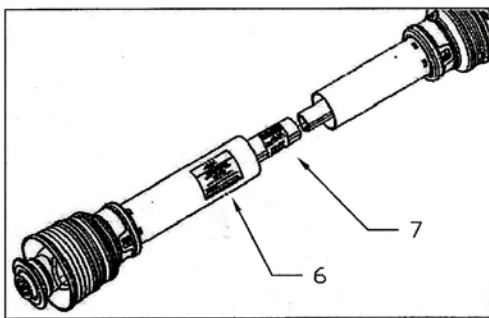
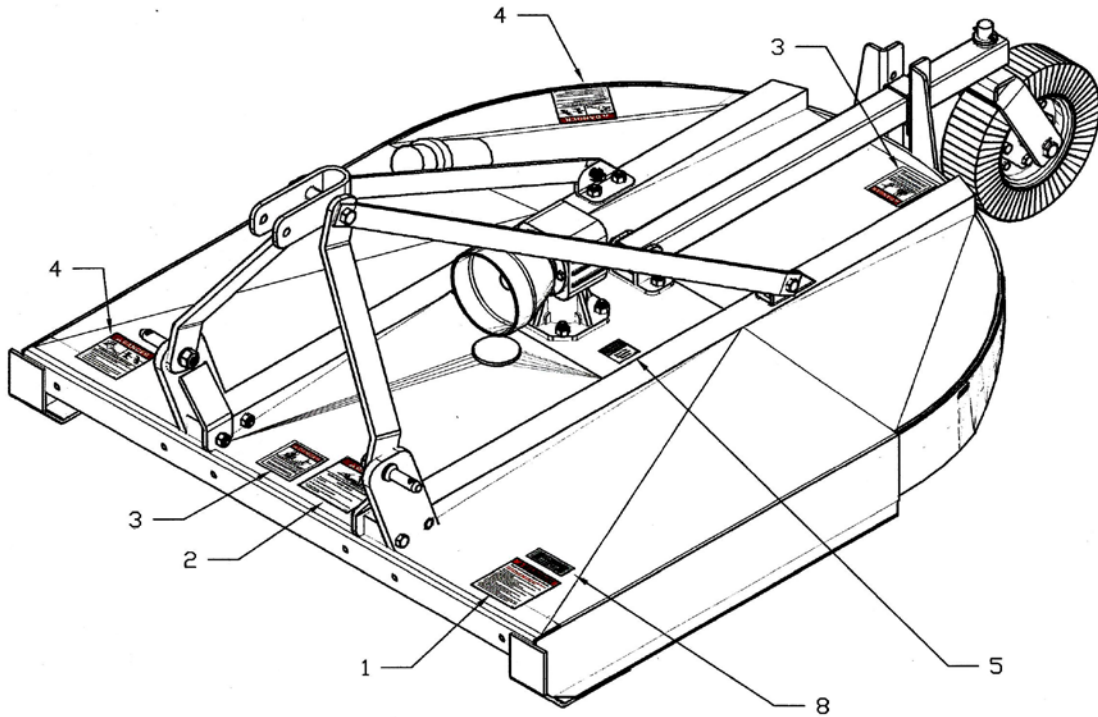



# SAFETY SIGN LOCATIONS

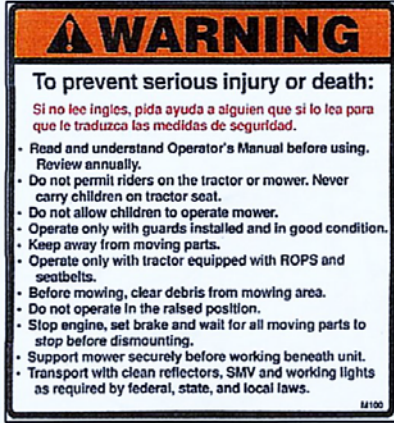

ITEM 1



ITEM 2



ITEM 3 (2)



ITEM 4 (2)



ITEM 5

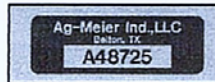

ITEM 8



Safety label for plastic guard tube

ITEM 6



ITEM 7

ITEMS 1-5 ARE ON THE SAFTY DECAL SHEET, PART # EC-1.

REMEMBER: If Safety Signs have been damaged, removed, become illegible or parts replaced without decals, new decals must be applied. New decals are available from your authorized distributor or factory.



## **SAFETY DECAL CARE**

- Keep safety signs clean and legible at all times.
- Replace safety signs that are missing or have become illegible.
- Replaced parts that displayed a safety sign should also display the current sign.
- Safety signs are available from your Distributor or Dealer Parts Department or the factory.

### **How to Install Safety Signs:**

- Be sure that the installation area is clean and dry.
- Decide on the exact position before you remove the backing paper.
- Remove the smallest portion of the split backing paper.
- Align the decal over the specified area and carefully press the small portion with the exposed sticky backing in place.
- Slowly peel back the remaining paper and carefully smooth the remaining portion of the decal in place.
- Small air pockets can be pierced with a pin and smoothed out using the piece of decal backing paper.



## **LIGHTING AND MARKING**

- It is the responsibility of the customer to know the lighting and marking requirements of the local highway authorities and to install and maintain the equipment to provide compliance with the regulations. Add extra lights when transporting at night or during periods of limited visibility.
- Lighting kits are available from your dealer or from the manufacturer.





## BEFORE OPERATION

- Carefully study and understand this manual.
- Do not wear loose-fitting clothing which may catch in moving parts.
- Always wear protective clothing and substantial shoes.
- Keep wheel lug nuts or bolts tightened to specified torque.
- Assure that agricultural implement tires are inflated evenly.
- Give the unit a visual inspection for any loose bolts, worn parts or cracked welds, and make necessary repairs. Follow the maintenance safety instructions included in this manual.
- Be sure that there are no tools lying on or in the equipment.
- Do not use the unit until you are sure that the area is clear, especially children and animals.
- Don't hurry the learning process or take the unit for granted. Ease into it and become familiar with your new equipment.
- Practice operation of your equipment and its attachments. Completely familiarize yourself and other operators with its operation before using.
- Use a tractor equipped with a Roll Over Protective System (ROPS) and fasten your seat belt prior to starting the engine.
- The manufacturer does not recommend usage of tractor with ROPS removed.
- Move tractor wheels to the widest recommended settings to increase stability.
- Securely attach to towing unit. Use a high strength, appropriately-sized hitch pin with a mechanical retainer and attach safety chain.
- Do not allow anyone to stand between the tongue or hitch and the towing vehicle when backing up to the equipment.



## DURING OPERATION

- Children should never be allowed on the equipment.
- Clear the area of small children and bystanders before moving the equipment.
- Shift towing unit to a lower gear before going down steep downgrades, thus using the engine as a retarding force. Keep towing vehicle in gear at all times. Slow down for corners and rough terrain.
- Make sure you are in compliance with all local and state regulations regarding transporting equipment on public roads and highways. Lights and slow moving signs must be clean and visible by overtaking or oncoming traffic when equipment is transported.
- SAFETY CHAIN - If equipment is going to be transported on a public highway, a safety chain should be obtained and installed. Always follow state and local regulations regarding a safety chain and auxiliary lighting when towing farm equipment on a public highway. Be sure to check with local law enforcement agencies for your own particular regulations. Only a safety chain (not an elastic or nylon/plastic tow strap) should be used to retain the connection between the towing and towed machines in the event of separation of the primary attaching system.
- Install the safety chain by crossing the chains under the tongue and secure to the draw bar cage or hitch or bumper frame.
- Beware of bystanders, **particularly children!** Always look around to make sure that it is safe to start the engine of the towing vehicle or move the unit. This is particularly important with higher noise levels and quiet cabs, as you may not hear people shouting.
- **NO PASSENGERS ALLOWED** - Do not carry passengers anywhere on, or in, the tractor or equipment, except as required for operation.
- Keep hands and clothing clear of moving parts.
- Always keep all shields and guards in place and securely fastened.
- Do not clean, lubricate or adjust your equipment while it is moving.
- When halting operation, even periodically, set the tractor or towing vehicle brakes, disengage the PTO, shut off the engine and **remove the ignition key**.
- Be especially observant of the operating area and terrain - watch for holes, rocks or other hidden hazards. Always inspect the area prior to operation.
  - **DO NOT** operate near the edge of drop-offs or banks.
  - **DO NOT** operate on steep slopes as overturn may result.
  - Operate up and down (not across) intermediate slopes. Avoid sudden starts and stops.



## HIGHWAY AND TRANSPORT OPERATIONS

- Adopt safe driving practices:
  - Keep the brake pedals latched together at all times. **NEVER USE INDEPENDENT BRAKING WITH MACHINE IN TOW AS LOSS OF CONTROL AND/OR UPSET OF UNIT CAN RESULT.**
  - Always drive at a safe speed relative to local conditions and ensure that your speed is low enough for an emergency stop to be safe and secure. Keep speed to a minimum.
  - Reduce speed prior to turns to avoid the risk of overturning.
  - Avoid sudden uphill turns on steep slopes.
  - Always keep the tractor or towing vehicle in gear to provide engine braking when going downhill. Do not coast.
  - Do not drink and drive!
- Comply with state and local laws governing highway safety and movement of farm machinery on public roads.
- Use approved accessory lighting flags and necessary warning devices to protect operators of other vehicles on the highway during daylight and nighttime transport. Various safety lights and devices are available from your dealer.
- The use of flashing amber lights is acceptable in most localities. However, some localities prohibit their use. Local laws should be checked for all highway lighting and marking requirements.
- When driving the tractor and equipment on the road or highway under 20 mph at night or during the day, use flashing amber warning lights and a slow moving vehicle (SMV) identification emblem.
- Plan your route to avoid heavy traffic.
- Be a safe and courteous driver. Always yield to oncoming traffic in all situations, including narrow bridges, intersections, etc.
- Be observant of bridge loading ratings. Do not cross bridges rated lower than the gross weight as which you are operating.
- Watch for obstructions overhead and to the side while transporting.
- Always operate equipment in a position to provide maximum visibility at all times. Make allowances for increased length and weight of the equipment when making turns, stopping the unit, etc.

- Pick the levellest possible route when transporting across fields. Avoid the edges of ditches or gullies and steep hillsides.
- Be extra careful when working on inclines.
- Maneuver the tractor or towing vehicle at safe speeds.
- Avoid overhead wires or other obstacles. Contact with overhead lines could cause serious injury or death.
- Avoid loose fill, rocks and holes; they can be dangerous for equipment operation or movement.
- Allow for unit length when making turns.
- Operate the towing vehicle from the operator's seat only.
- Never stand alongside of unit with engine running or attempt to start engine and/or operate machine while standing alongside of unit.
- Never leave running equipment attachments unattended.
- As a precaution, always recheck the hardware on equipment following every 100 hours of operation. Correct all problems. Follow the maintenance safety procedures.



## **FOLLOWING OPERATION**

- Following operation, or when unhitching, stop the tractor or towing vehicle, set the brakes, disengage the PTO and all power drives, shut off the engine and **remove the ignition keys**.
- Store the unit in an area away from human activity.
- Do not park equipment where it will be exposed to livestock for long periods of time. Damage and livestock injury could result.
- Do not permit children to play on or around the stored unit.
- Make sure all parked machines are on a hard, level surface and engage all safety devices.
- Wheel chocks may be needed to prevent unit from rolling.



## PERFORMING MAINTENANCE

- Good maintenance is your responsibility. Poor maintenance is an invitation to trouble. Proper servicing and adjustments are key to the long life of any implement. With careful inspection and routine maintenance, costly downtime and repairs can be avoided.
- Some parts and assemblies can be quite heavy. Before attempting to unfasten any part or assembly, arrange to support it by means of a hoist, by blocking or by use of an adequate arrangement to keep it from falling, tipping, swinging or moving in any manner which may hurt somebody or damage the equipment.
- Always use lifting equipment that is adequately rated to do the job. Never lift equipment over people.
- Make sure there is plenty of ventilation. Never operate the engine of the towing vehicle in a closed building. The exhaust fumes may cause asphyxiation.
- Before working on the equipment, stop the towing vehicle, set the brakes, disengage the PTO and all power drives, shut off the engine and **remove the ignition keys**.
- Be certain all moving parts on attachments have come to a complete stop before attempting to perform maintenance.
- **Always** use a safety support and block the wheels. Never use a jack to support the equipment.
- Always use the proper tools or equipment for the job at hand.
- Use extreme caution when making adjustments.
- Never replace hex bolts with less than grade five bolts unless otherwise specified.
- After servicing, be sure all tools, parts and service equipment are removed.
- Where replacement parts are necessary for periodic maintenance and servicing, genuine factory replacement parts must be used to restore your equipment to original specifications. The manufacturer will not claim responsibility for use of unapproved parts and/or accessories and other damages as a result of their use.
- If equipment has been altered in any way from original design, the manufacturer does not accept any liability for injury or warranty.
- If repairs require the use of a torch or electric welder, be sure that all flammable and combustible materials are removed.
- Do not weld or cut on any tank containing oil, fuel or their fumes or other flammable material, or any container whose previous contents are unknown.

- Cleaning solvents should be used with care. Petroleum based solvents are flammable and present a fire hazard. Don't use gasoline. All solvents must be used with adequate ventilation and their vapors should not be inhaled.



## HYDRAULIC FLUID AND EQUIPMENT SAFETY

Only adequately trained and qualified persons should work on hydraulics systems. You may be severely injured or killed by being crushed under a falling piece of equipment. Always have transport locks in place and frame sufficiently blocked when working on any implement.

Hydraulic fluid escaping under pressure can have sufficient force to cause injury. Keep all hoses and connections in good serviceable condition. Failure to heed may result in serious personal injury or death. Escaping hydraulic fluid under pressure can have sufficient pressure to penetrate the skin causing serious injury. Avoid the hazard by relieving the pressure before disconnecting lines or performing work on the system.

Make sure hydraulic fluid connections are tight and all hydraulic hoses and lines are in good condition before applying pressure to the system. Use a piece of paper or cardboard, NOT BODY PARTS, to check for suspected leaks. Wear protective gloves and safety glasses or goggles when working with hydraulic systems. DO NOT DELAY! If an accident occurs, see a doctor familiar with this type of injury immediately. Any fluid injected into the skin or eyes must be treated within a few hours or gangrene may result.

Always secure equipment with solid supports before working on or under it. Never work under equipment supported by hydraulics. Hydraulics can drop equipment if controls are actuated or hydraulic lines burst or pressure is lost while disconnecting lines. Either situation can drop machinery instantly even when power to hydraulics is off. Do not attempt to disconnect a hydraulic cylinder or hose while the system is under pressure!

Check hydraulic hoses and fittings frequently. Brush and other debris can damage hoses and fittings. Inspect and maintain equipment daily. Loose, broken, and missing hardware can cause equipment to not perform properly and can result in bodily injury or death.

Hydraulic systems and oil can be hot and cause burns. Before working on any system, wait until the oil has cooled.



## LOCKOUT / TAGOUT

**Think, plan and check.** **Think** through the entire procedure and identify all the steps that are required. **Plan** what personnel will be involved, what needs to be shut down, what guards need to be removed, and how (and under what conditions) the power will be restarted. **Check** the machine over to verify all power sources and stored energy have been identified including engines, hydraulic and pneumatic systems, springs and accumulators, and suspended loads, Shutoff and lockout power before adjusting, servicing, maintaining, or clearing an obstruction

from this machine. Failure to heed may result in serious injury or death. Communicate with everyone involved in a repair or maintenance operation, including bystanders, that work is being done which involves keeping this machine safety at a ZERO ENERGY STATE.

OSHA's requirements for lockout/tag out are covered in Section 1910.147 of the OSHA standards. The LOTO standard establishes the employer's responsibility to protect workers from hazardous energy. Employers are required to train each worker to ensure that they know, understand, and are able to follow the applicable provisions of the hazardous energy control procedures:

- Proper lockout/tag out (LOTO) practices and procedures safeguard workers from the release of hazardous energy. The OSHA standard for The Control of Hazardous Energy (Lockout/Tag out) for general industry, outlines specific action and procedures for addressing and controlling hazardous energy during servicing and maintenance of machines and equipment. Employers are also required to train each worker to ensure that they know, understand, and are able to follow the applicable provisions of the hazardous energy control procedures. Workers must be trained in the purpose and function of the energy control program and have the knowledge and skills required for the safe application, usage and removal of the energy control devices.
- All employees who work in the area where the energy control procedure(s) are utilized need to be instructed in the purpose and use of the energy control procedure(s) and about the prohibition against attempting to restart or reenergize machines or equipment that is locked or tagged out.
- All employees who are authorized to lockout machines or equipment and perform the service and maintenance operations need to be trained in recognition of applicable hazardous energy sources in the workplace, the type and magnitude of energy found in the workplace, and the means and methods of isolating and/or controlling the energy.
- Specific procedures and limitations relating to tagout systems where they are allowed.
- Retraining of all employees to maintain proficiency or introduce new or changed control methods.

OSHA outlines a six-step procedure for controlling hazardous energy:

- **Step 1: Prepare for shutdown.** It must be determined what type of power system is going to be deactivated including electrical, hydraulic, pneumatic or other energy sources. Knowledge of shut down methods is necessary.
- **Step 2: Shutdown the equipment.** This should be completed consistent with the manufacturer's instructions for the shutdown procedure and could be as simple as placing a switch in the "off" position or pressing a button.
- **Step 3: Isolate the equipment.** This step involves closing of valves, throwing the main disconnects or circuit breakers and disconnecting or capping any auxiliary power sources or secondary electrical systems.
- **Step 4: Apply the lockout/tag out device.** This is done to prevent restoration of the flow of energy and is done at all disconnect switches, valves or other energy isolating devices. Locks are the preferred method of controlling energy and should be

supplemented with tags. Various lockout devices are available including group lockout hasps. Locks should be individually assigned and have only one key.

- **Step 5: Control the stored energy.** This step includes the release, disconnect or restraint of any residual hazardous energy which may be present and a check that all moving parts have stopped moving. It may also include the installation of “pancakes” or blanking of pipe flanges, the installation of ground wires to discharge electrical capacitors and the blocking or supporting of elevated equipment.
- **Step 6: Verify isolation of equipment.** Double-check the steps and verify that the equipment indeed has been shut down and that the lock and tag do control the stored energy. Employees should be warned and the system tested, including pressing of all start buttons to assure that the equipment will not start.



## **Rotary Cutter Safe Practices Messages from the American Society of Agricultural and Biological Engineers**

The following safe practices are recognized as being effective for enhancing safety, if followed, but may not be adequate, complete, or entirely applicable for every situation. They may not cover all possible hazardous situations; hence, they should be interpreted judiciously.

- Personal protective equipment such as, but not limited to, gloves, safety glasses, hard hat, and safety shoes should be worn when hazards to personal safety exist when operating mowers.
- Lower mower, disengage PTO, stop engine, remove key, de-energize hydraulics, set brake, and wait for all moving parts to stop before dismounting to park or service equipment.
- Securely support or block up before working underneath any lifted mower or component to avoid injury or death from inadvertent dropping due to hydraulic leak down, mechanical or hydraulic system failure, or inadvertent operation of controls.
- The tractor must be equipped with a roll-over protective structure (ROPS) except where the use of ROPS would create an additional hazard. The operator must fasten seat belt snugly prior to starting engine on tractors having ROPS in place. Avoid accidental fall-off or possible injury or death from tractor or equipment run-over by using seat belt during mowing operations.
- Operate the mower from the operator's seat only.
- Do not allow riders on the mower.
- Do not allow rider on the tractor unless there is a seat belt-equipped position that is ROPS-protected for each rider.
- Visually check for hydraulic leaks and broken, missing, or malfunctioning parts, and make necessary repairs. Do not use your hand to check for leaks: use cardboard or similar material. Escaping hydraulic oil under pressure can have sufficient force to penetrate the skin and cause a serious personal injury or death. The injected fluid may result in gangrene if the fluid is not surgically removed immediately by a doctor familiar with this form of injury.
- Before disconnecting hydraulic lines, release all hydraulic pressure.
- Keep implement input driveline, implement input connection, and tractor PTO shield in place and in good condition when operating. Be sure the driveline is securely locked onto the PTO.
- Do not open access doors or remove guards until rotating components have stopped.
- Mowers that are provided with intake and/or discharge shield that may be subject to routine wear or deterioration must be inspected regularly and maintained as instructed by the manufacturer in the operator's manual.
- Make certain the slow moving vehicle (SMV) sign and other reflectors are clearly visible. Follow local traffic codes for slow moving vehicles when transporting on public roads.
- Attach safety chain between towed mower and propelling machine as shown in operator's manual before towing on public roads.

# OPERATION

## TRACTOR PREPERATION

### BALLAST (FRONT END WEIGHT)

Add enough weight to assure at least 20% of the tractors original weight is on the front wheels for safe transport.

### WHEEL TREAD

Tractor wheel tread spacing should be increased when working on incline or rough ground to reduce the possibility of tipping.

### STABLIZER BARS OR SWAY BLOCKS

Use stabilizer bars or sway blocks to prevent side sway of the cutter.

### DRAFT LINKS

The linkage to the lower draft links should be set in the “Float Position”, allowing the unit to Follow the contour of the terrain.

### DRAWBAR

Shorten or remove drawbar so it will not interfere with the up and down movement of the cutter.

## MOUNTING THE CUTTER TO THE TRACTOR

**DANGER** A crushing hazard exists when hooking-up equipment to a tractor. Do not allow anyone to stand between tractor and implement while backing-up to implement. Do not operate hydraulic 3-point lift controls while someone is directly behind tractor near implement.



To mount the cutter, be sure it is sitting on as level ground as possible and follow the steps outlined in the manual for attaching a three-point hitch implement.

1. Slowly back up to the rotary cutter while using tractor's 3-point hydraulic control to align lower 3-point arm holes with the hitch pins.
2. Engage tractor park break, shut tractor engine off, and remove key before dismounting from the tractor.
3. Attach the cutter hitch pins to the lower three-point lift arms of the tractor.
4. Connect the tractor top link to the hole in the top of the A-Frame link or the cutter using the pin supplied. With the rotary cutter attached to the tractor's three-point hitch, proceed to connection of the PTO as follows
5. Slide the yoke with the quick disconnect pin onto the tractor PTO shaft. Move the yoke back and forth to insure it is locked onto the shaft.
6. Attach the safety chain to the stationary point to prevent the shield from spinning.
7. Return to the tractor and slowly raise and lower the cutter to ensure that the drawbar, tires, and other equipment on the tractor do not make contact with the cutter frame and driveline. Move or remove drawbar if needed.
8. Adjust the lower lift arms on the tractor to level the cutter from left to right.
9. Adjust the length of the top-link to level the cutter from front to rear.

# OPERATION

## **IMPORTANT: CHECK DRIVELINE LENGTH**

A driveline that is too long can bottom out causing damage to the tractor and cutter. Always check the driveline collapsed length during initial setup, when connecting to a different tractor, and when alternating between using a quick hitch and a standard 3-point hitch.

Telescoping tubes must always overlap by at least  $\frac{1}{2}$  of their length in normal operations and at least  $\frac{1}{3}$  of their length in all working conditions.

## **TRANSPORTING**

Pay particularly close attention to the SAFETY MESSAGES regarding cutter transport. Avoid unnecessary injuries and equipment damage by exercising cautious and conscientious travel procedures.

Attaching the cutter to the tractor increases the overall length of the working unit. Allow additional clearance for the cutter to swing when turning.

Raise the cutter as high as possible for transporting while maintaining clearance between the driveline and the deck of the cutter.

Tire pressure should be kept at around 20 PSI to decrease shock during transport. When using puncture-proof, laminated tires, be sure that the flat side of the lug nut is against the wheel.

## **WARNING**



When transporting the cutter on a road or highway, use tractor warning lights, SMV sign, reflectors and other safety devices for adequate warning to the operators of other vehicles

Check the traffic regulations governing locale where mowing is to be done and work safely within those guidelines

Be sure that the tractor lift lever is locked into the "transport" detent before attempting to transport the cutter. Make sure that at least 20% of the tractor weight is on the front tires.

## **WARNING**



Hold transport speed to 15 mph, especially when using puncture-proof, laminated tires. These tires are designed for off road use only. They can be used on road surfaces at very low speeds for a short distance. Heat from pavement friction can build up causing the tire to ignite. The steel band holding the sections in place could break, causing extensive damage to the cutter and tractor as well as possible injury to the operator and passerby. When transporting up slopes with reduced front end weight the tailwheel should be lowered as far as possible to provide a stop if the tractor rears up.

## **CUTTING HEIGHT ADJUSTMENT**

### **WARNING**



Avoid personal injury. Be sure the tractor engine is off and the key is removed before making and adjustments.

**IMPORTANT:** Avoid very low cutting heights. Striking the ground with the blades gives the most damaging shock loads a cutter can encounter and will cause damage to the cutter and driveline.

# OPERATION

To achieve maximum cutting efficiency and provide the most uniform cut, the cutter should be operated with the rear slightly higher (1/2"-3/4") than the front.

1. Place the tractor and cutter on level surface
2. Raise the cutter to the approximate desired cutting height with the tractor hydraulic lift control lever.
3. Remove the gauge wheel adjusting bolt from the rear adjusting brackets. Adjust the gauge wheel leg to the desired cutting height and reinstall the bolt.
4. Lower slowly until the cutter is 1/2"-3/4" higher at the rear than the front. Position the adjustable stop on the tractor lift quadrant against the lift control lever so that the cutter can be returned to the same cutting height.

**IMPORTANT:** When raising the cutter to transport height, be sure there is clearance between the front of the deck and driveline. Damage will result if the driveline hits the cutter deck.

## STARTING AND STOPPING THE CUTTER

Power for operating the cutter is supplied from the tractor PTO. Refer to the tractor manual for instructions on engaging and disengaging the PTO. Always engage the PTO at low engine RPM. Always operate at 540 RPM. Learn how to stop the tractor and cutter quickly in case of an emergency.

**IMPORTANT:** Stop the cutter and the tractor immediately upon striking an obstruction. Inspect the cutter and repair before resuming operation.

## WARNING



Avoid personal injury. When attempting to stop a tractor which does not have live PTO, the momentum created by the cutter can cause the tractor to be pushed forward.

The installation of an overrunning clutch is recommended if the operating tractor does not have live power take off. See your dealer for additional information.

To start operation, reduce engine speed and engage the tractor PTO. Before starting to cut, gradually increase engine speed to develop 540 RPM at the PTO.

## DANGER



Install chain guards if operating with people or livestock in the area or close to highways or buildings.

Enter the area to be cut with the cutter operating at 540 RPM and, if it becomes necessary to temporarily regulate engine speed during operations, increase or decrease throttle gradually - **never exceed 540 RPM.**

To transport, disengage the PTO and raise the machine to full transport height.

# OPERATION

## CUTTING SPEED

Proper ground speed for the cutter will depend upon the height, type and density of the material to be cut. Normally, ground speed will range from 2 to 5 mph. Tall dense material should be cut at low speed, while medium height material can be cut at a faster ground speed.

## CUTTING TIPS

Always operate PTO at 540 RPM when cutting. This is necessary to maintain proper blade speed to produce clean cut. Under certain conditions, the tractor tires may roll some of the grass down and prevent it from being cut at the same height as the surrounding area. When this occurs, reduce the tractor ground speed, but maintain 540 PTO RPM. The lower speed will permit the grass to partially rebound and be cut. Taking a partial cut or reversing the direction of travel may also produce a cleaner cut.

## WARNING



Avoid personal injury. Pick up all rocks and other debris before cutting. Enter new areas carefully. Drive slowly and cut material higher the first time to allow the cutter to clear unseen objects. Never assume an area is clear. Always check for hidden hazards.

Extremely tall grass should be cut twice. Raise the cutter and cut twice the desired height. Cut the second time at the desired height at 90 degrees to the first pass.

Remember, sharp blades produce cleaner cuts and use less power. Before cutting, study the area to determine the best cutting procedures. Consider the height and type of material and the terrain type: hilly, level, or rough.

**Avoid tractor rollovers:** Be careful when operation the tractor and cutter on uneven ground. Equip your tractor with a roll bar (ROPS) and seat belts. Keep seat belts tightened securely.

In uneven terrain, rear wheel weights, front tractor weight and/or front tire ballast should improve stability. Pass diagonally through sharp dips and avoid drops to prevent "hanging up" the tractor and cutter.

Avoid sudden stops and starts while traveling up or down hills.

When cutting on slopes, always operate the cutter in a downward motion and do not travel across the face of a slope. Avoid operation on steep slopes. Slow down on sharp turns to prevent tipping or loss of control.

## MAINTANCE AND LUBRICATION

Proper servicing and adjustments are the key to the long life of any machine. With careful and systematic inspection of the Rotary Cutter, you can avoid costly maintenance, time and repair.



**WARNING:** For safety reasons, each maintenance operation must be performed with the PTO shaft disengaged, cutter lowered completely to the ground or on safety supported blocking, the tractor engine shutoff and the ignition key removed.

# MAINTENANCE

## LUBRICATE DAILY:

1. PTO U-Joints & Profiles
2. Tailwheel spindle tube
3. Tailwheel hub

## GEARBOX

Lubricate every 50 hours of operation. On the Brave 4, 5 & 6, the flange mounted gearbox oil reserve is 26 ounces. If the oil reserve is below normal level, check for a crack in the gearbox or leaking seal. The oil must be checked after every 10 hours of operation. If oil flows out of the 1/8" oil level plug the proper lubrication level is being maintained. If oil does not flow out of the plug, add oil until it does.

Recommended lubricant is SAE80w-90EP oil. Check the oil in the gearbox when the cutter is level. **DO NOT** over fill the gearboxes. This will cause pressure to build up and cause oil seals to leak.

## UNIVERSAL JOINTS

Grease fittings are located on the cross of each U-Joint, Grease after each 10 hours of use.

## DRIVELINE

The telescoping PTO shaft inside the shielding must be lubricated daily.

Disconnect the driveline from the tractor and pull the halves apart. Insert grease into the cavity on the half attached to the gearbox and spread evenly. Install the driveline halves together.

Reconnect the driveline to the tractor. Raise and lower the cutter after applying grease to spread over working joint area.



**WARNING:** When attaching the PTO yoke to the tractor PTO shaft, it is important that the spring activated locking pin is seated in the groove on the PTO shaft. A loose shaft could slip off and result in personal injury or damage to the cutter.

## SLIP CLUTCH (OPTIONAL)

If a slip clutch is incorporated in the driveline, it is designed to slip, absorb the shock load, and protect the driveline and cutter. **NOTE:** Slip clutch units use a Grade 8 bolt to retain the clutch to the gearbox shaft. Always use Grade 8 bolts when replacing.

As with any torque limiter, damage can still occur to the blades or drive train before they slip; therefore, it is still the operator's responsibility to ensure that the area is clear of any obstructions that could damage the machine.

**MACHINES SO DAMAGED ARE NOT COVERED BY WARRANTY.**

Prior to the initial start-up operation and after periods of inactivity, the slip clutches should be "RUN-IN" before the cutter is used again. This can be accomplished by using the following procedure:

1. Carefully loosen each of the 8 spring retaining nuts by 2 revolutions.
2. Start the tractor and engage the PTO for 2-3 seconds two times to permit slippage. Disengage the PTO, shut off the tractor, and remove the key.
3. Inspect the clutch and ensure the clutch plates have slipped. A clutch that has not slipped must be disassembled to separate the friction disc plates.
4. Tighten each of the 8 spring retainer nuts 2 revolutions to restore the clutch to the original setting pressure.

The manufacturer's recommended setting for this clutch is a compressed spring length of 1.14". By performing this procedure, the operator makes sure that the clutches are performing correctly and are set properly.

# MAINTENANCE

## SERVICING CUTTING BLADES

### WARNING



Use only **AG-MEIER INDUSTRIES LLC** blades. They are made specifically for this cutter. Substitute blades may not meet Specifications and could be dangerous.

For servicing of the blades, the manufacturer has provided an access hole in the cutter deck on BRAVES.

All blades must be replaced or reground at the same time to maintain proper balance in the cutting unit.

Keep all blade bolts tight and, for better cutting, keep all blades sharp. Inspect the blades before each use to determine that they are properly installed and in good condition. Replace any blade that is bent, excessively nicked, worn or has any other damage. Small nicks can be ground out when sharpening.

### BLADE CARRIER

Always disconnect the driveline from the tractor and block the cutter securely before working on the blades or blade carrier.

Inspect the blade carrier frequently. After operation, check the blade carrier hub for tightness on the gearbox output splined shaft. Keep all blade bolts tightened to 600 ft. lbs. and, for better cutting, keep all blades sharp. Always use **AG-MEIER INDUSTRIES LLC** blades. When replacing blades, check the cutting edges in relation to the blade carrier rotation. For removing the blade carrier hub from the gearbox, use a drift punch through the access hole or gear puller. DO NOT hammer on the end of the gearbox output shaft, as this may cause damage to the bearings.

### TO REPLACE BLADES

1. Sharpening all blades at the same time to maintain proper balance in the cutting unit.
2. Order **AG-MEIER INDUSTRIES LLC** blades and blade bolt kit.
3. Torque blade bolt lock nut to 600 ft. pounds. An extended cheater bar may be required to achieve proper torque.

### BLADE SHARPING

1. Replace all blades at the same time to maintain balance. The difference in blade weight should not exceed 1 ounce. Unbalanced blades will cause excessive vibration which can damage gearbox bearings. Vibration may cause structural cracks in the cutter housing.
2. Examine bolts for excessive wear and replace if necessary.
3. Follow the original pattern of the blade.
4. Sharpen the blades by grinding. Do not heat and pound out the edge. Do not sharpen to a razor edge, but leave a 1/16" blunt edge. Do not sharpen the back side of the blade. See Figure 13.

NOTE: Care should be taken in order not to remove any more material than necessary when sharpening the blades.

All blades should be sharpened at the same angle as the original cutting edge.

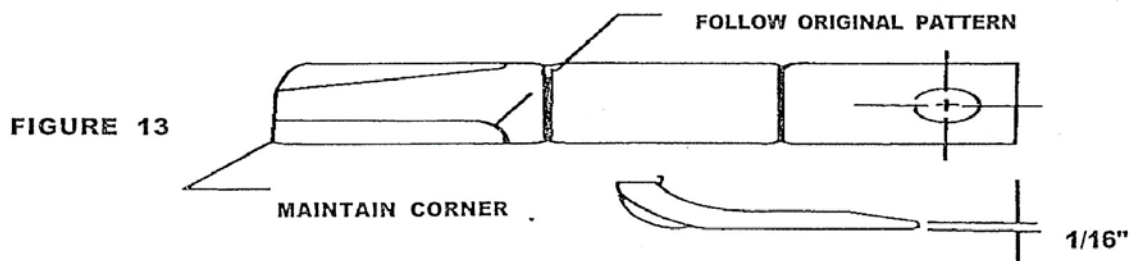

# MAINTENANCE

## STORAGE

Your rotary cutter represents an investment from which you should get the greatest possible benefit. Therefore, when the season is over, the cutter should be thoroughly checked and prepared for storage so that a minimum amount of work will be required to put it back into operation for the next season. The following are the suggested storage procedures.

1. Thoroughly clean the cutter
2. Lubricate the cutter as covered in the Maintenance Section.
3. Tighten all bolts to recommended torque.
4. Check the cutter for worn or damaged parts. Make replacements immediately using Genuine **AG-MEIER IND. L.L.C.**
5. Store the cutter in a clean, dry place with the cutter housing resting on blocks.
6. Use spray touch-up enamel where necessary to prevent rust and maintain appearance of the cutter.



# TROUBLE SHOOTING GUIDE

<u>TROUBLE</u>	<u>POSSIBLE CAUSE</u>	<u>POSSIBLE REMEDY</u>
Excessive Vibration	1. Check gearbox bolts	Tighten if loose
	2. Check for loose nuts on blade Holder and blades	Tighten if loose
	3. Check for bent output shaft. If Shaft is bent, oil will normally leak from bottom of seal	Replace shaft if bent
	4. Check to see if blades are free swinging	Free blades so they swing
	5. Check for even wear on each blade tip. Were all blades changed at the same time.	Weigh blades. Weight should be within 1oz. Always replace both blades
	6. Blade broken	Replace blades, in sets
	7. Blade carrier bent	Replace blade carrier
<b>GEAROX OVERHEATING</b>	1. Low on lubricant	Fill to level plug
	2. Improper type of lubricant	Replace with proper lubricant
	3. Excessive trash build up around gearbox	Remove trash
	4. Bearing or gears set up improperly	Consult your dealer
<b>NOT CUTTING CLEAN</b>	1. Blades dull	Sharpen or replace blades
	2. Carrier RPM to low	Use correct PTO speed and Check for correct gearbox ratio
	3. Cutter not level	See cutting height adjustment
	4. Tractor tires mashing down on grass	Reverse direction of cutting and drive with one tractor tire out of cutter overlap area. Conditions to wet to cut.
	5. Ground speed to fast	Reduce ground speed by Shifting to lower gear
	6. Blades locked back	Free blades
	7. Blades riding up due to wear or loose bolts	Replace blade bolts

# TROUBLE SHOOTING GUIDE

<u>TROUBLE</u>	<u>POSSIBLE CAUSE</u>	<u>POSSIBLE REMEDY</u>
STREAKING CONDITIONS	1. Conditions to wet for cutting. Blades unable to cut that part of grass pressed Down by path or tractor tires	Allow grass to dry before cutting. Slow ground speed of tractor but keep engine at full PTO RPM. Cutting lower may help.
	2. Dull blades	Sharpen or replace blades
	3. Height of cutter lower at front or rear	See cutting height instructions
BLADE BOLTS LOOSE	1. Bolts not tightened	Tighten bolts to 350 ft. lbs.
	2. Bolt hole elongated or oversized	Replace blade carrier
	3. Lock nut worn out	Replace lock nut
GEARBOX NOISY	1. Rough gears	Run in or change gears
	2. Worn bearings	Replace bearings
GEARBOX LEAKING	1. Damaged oil seal	Replace seal
	2. Bent shaft	Replace oil seal & shaft
	3. Oil seal installed wrong	Replace seal
	4. Oil level to high	Drain oil to proper level
	5. Pin hole leak in gearbox housing	Replace housing or gearbox
	6. Gasket damaged	Replace gasket
	7. Bolts loose	Tighten bolts
SHEAR PIN SHEARS EXCESSIVELY	1. Tractor PTO not being run at 540 RPM	Run at 540 RPM
	2. Heavy Material	Reduce ground speed. raise cutting height
	3. Not using proper pin	Replace, only with recommended pin
CLUTCH SLIPS EXCESSIVELY	1. Not operating at 540 RPM	Run at 540 RPM

# TROUBLE SHOOTING GUIDE

**TROUBLE**  
CLUTCH SLIPS  
EXCESSIVELY  
(CONT.)

**POSSIBLE CAUSE**

2. Too much load on clutch
3. Oil on facing
4. Clutch linings worn or plates warped

**POSSIBLE REMEDY**

Reduce ground speed &  
material intake

Replace facings

Repair clutch per  
maintenance section

**BLADE WEAR  
TO FAST**

1. Cutting in sandy conditions
2. Cutting in rocky conditions

Increase cutting height. keep  
blade at least 1" above the  
Ground

Increase cutting height

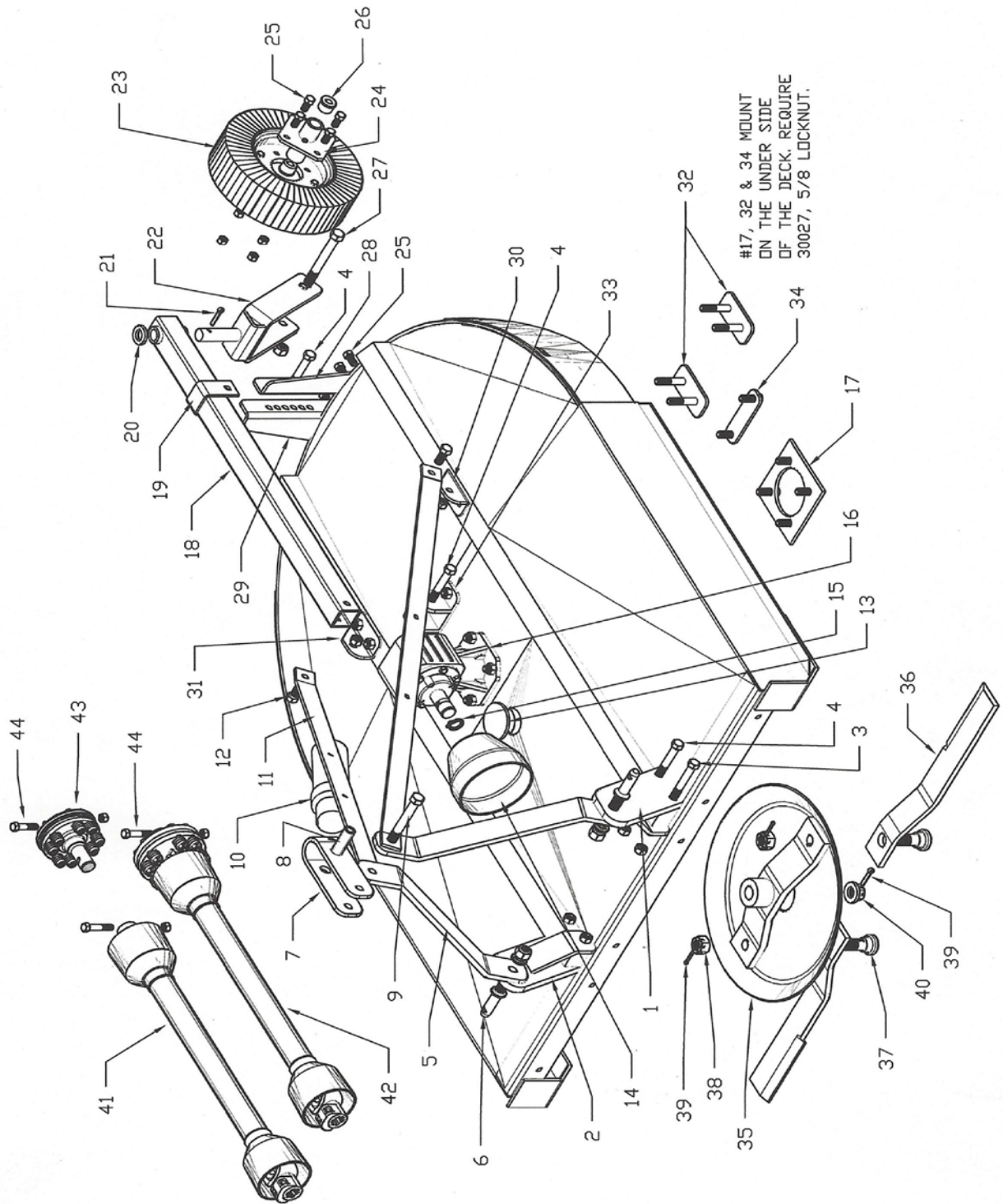

# BRAVE 4, 5, 6

REF.	PART NO.	DESCRIPTION	QTY.
1.	30900492	HITCH ARM LUG, LEFT, BRAVE 5 & 6	1
2.	30900491	HITCH ARM LUG, RIGHT, BRAVE 5 & 6	1
3.	10100552	HEX BOLT, 5/8 X 5	2
4.	31378	HEX BOLT, 5/8 X 4-1/2	4
5.	30900363	3 POINT HITCH ARM MAST	2
6.	KTR161	CAT 1 PIN	2
7.	30900447	TOP LINK CLEVIS	1
8.	30900448	PIVOT BUSHING	1
9.	32517	HEX BOLT, 3/4 X 6	1
	30032	HEX LOCK NUT, 3/4	1
10.	OMG-1	OWNERS MANUAL CANISTER	1
	30042	HEX BOLT, 1/4 X 1	2
	30133	FLAT WASHER, 1/4	4
	30122	LOCK WASHER, 1/4	2
	30015	HEX NUT, 1/4	2
11.	22713	REAR LINK	2
12.	30084	HEX BOLT, 5/8 X 1-1/4	2
13.	32387	3" PLUG	1
14.	69351	INPUT SHIELD, SHEAR PIN	1
	74845	INPUT SHIELD, SLIP CLUTCH	1
	30246	HEX BOLT, 5/16 X 3/4	4
	30134	FLAT WASHER, 5/16	4
	30123	LOCK WASHER, 5/16	4
15.	30504	RETAINING RING	1
16.	31338	GEARBOX	1
17.	30900578	BACKUP PLATE FOR GEARBOX, BRAVE 5 & 6	1
18.	21966	WHEEL LEG, BRAVE 4 & 5	1
	30900449	WHEEL LEG, BRAVE 6	1
19.	22706	TAILWHEEL STRAP	1
20.	21886	WASHER	1
21.	30150	COTTER PIN, 1/4 X 2-1/4	1
22.	24870	TAILWHEEL YOKE	1
23.	33406	LAMMINATED TAILWHEEL	1
24.	33407	HUB, TAILWHEEL	1
25.	30068	HEX BOLT, 1/2 X 1-1/4	8
	30022	HEX LOCK NUT, 1/2	8
26.	33833	REPLACEMENT BUSHING, TAILWHEEL HUB	2
27.	33213	AXLE PIN	1
	30032	HEX LOCK NUT, 3/4	1
28.	30900452	TAILWHEEL MOUNT, LEFT	1
29.	30900491	TAILWHEEL MOUNT, RIGHT	1
30.	30900494	REAR LINK MOUNT ANGLE, LEFT, BRAVE 5 & 6	1
31.	30900493	REAR LINK MOUNT ANGLE, RIGHT, BRAVE 5 & 6	1
32.	30900495	BACKUP PLATE FOR REAR LINK MOUNT, BRAVE 5 & 6	2
33.	30900496	TAILWHEEL MOUNT, MID-DECK, BRAVE 5 & 6	1
34.	30900497	BACKUP PLATE FOR TAILWHEEL MNT., BRAVE 5 & 6	1
35.	30900450	BLADE PAN	1
36.	31467	BLADE, BRAVE 4	2
	31339	BLADE, BRAVE 5	2
	31777	BLADE, BRAVE 6	2
37.	10100822	BLADE BOLT, 1-1/8 X 2-1/2, DRILLED	2
38.	10200056	CASTLE NUT, 1-1/8 - 12, FOR BLADE BOLT	2
39.	30148	COTTER PIN, 3/16 X 2	3
40.	10200053	CASTLE NUT,	1
41.	50100506	DRIVELINE, SHEAR PIN	1
	30078	SHEAR BOLT, 1/2 X 3 GRADE 2	1
42.	50100508	DRIVELINE SLIP CLUTCH SMOOTH BORE (OPTIONAL)	1
43.	33253	SLIP CLUTCH, USE WITH 50100506 DRIVELINE (OPTIONAL)	1
44.	10100380	HEX BOLT, 1/2 X 3, GR 8 (DO NOT USE FOR SHEAR PIN)	1

# BRAVE GEARBOX

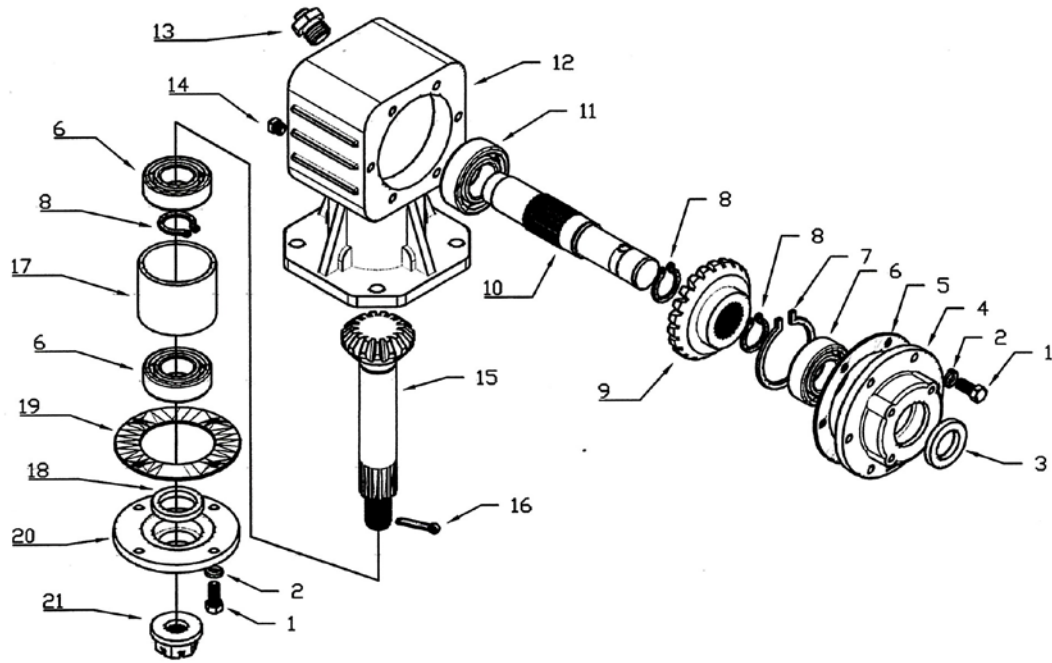

REF.	PART NO.	DESCRIPTION	QTY.
	31338	COMPLETE GEARBOX	1
1.	30053	HEX BOLT, 3/8 X 1	10
2.	30124	3/8 LOCKWASHER	10
3.	WA47-110D	OIL SEAL	1
4.	KTR211	INPUT CAP	1
5.	31368	INPUT CAP GASKET	1
6.	30977	208K BALL BEARING	3
7.	31367	INPUT CAP BEARING RETAINING RING	1
8.	31062	SNAP RING	3
9.	31363	INPUT GEAR, 22 TEETH	1
10.	31360	INPUT SHAFT	1
11.	GB022	207K BALL BEARING	1
12.	31357	HOUSING	1
13.	50200071	PRESSURE RELIEF PLUG	1
14.	31364	PIPE PLUG, 1/8"	1
15.	31362	OUTPUT PINION, 15 TEETH	1
16.	30148	3/16 X 2 COTTER KEY	1
17.	31361	OUTPUT BEARING SPACER	1
18.	30593	OUTPUT SHAFT SEAL	1
19.	KTR213	OUTPUT CAP GASKET	1
20.	31359	OUTPUT CAP	1
21.	10200053	FLANGE CASTLE NUT	1

## 50100506 DRIVELINE SHEAR PIN

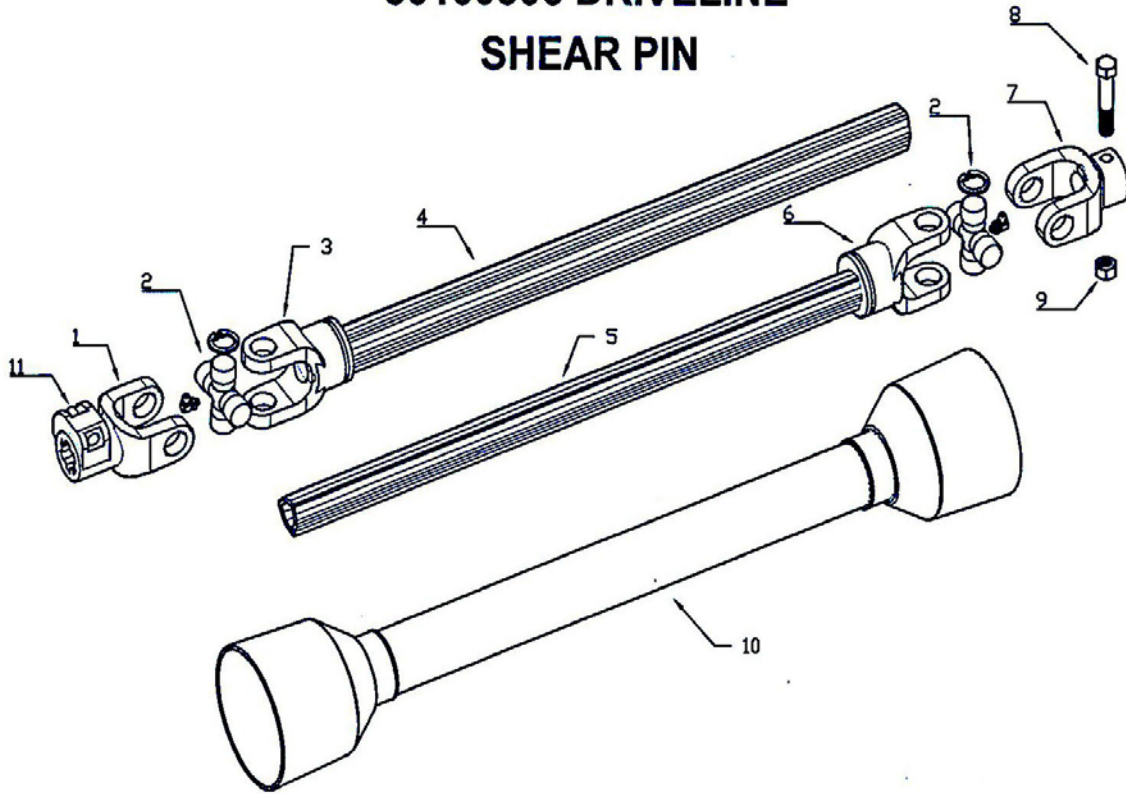

REF.	PART NO.	DESCRIPTION	QTY.
	50100506	COMPLETE DRIVELINE, SHEAR PIN	1
	50100526	COMPLETE TRACTOR HALF, WITH SHIELD	1
	50100527	COMPLETE IMPLEMENT HALF, WITH SHIELD	1
1.	31373	YOKE, 6 SPLINE TRACTOR END	1
2.	31370D	CROSS ASSEMBLY (CROSS, GREASE FITTING, 4 SNAP RINGS)	2
3.	31378D	YOKE	1
4.	33060D	OUTSIDE TUBE, CUT TO LENGTH	1
5.	33052D	INSIDE TUBE, CUT TO LENGTH	1
6.	31379D	YOKE	1
7.	32201D	YOKE, IMPLEMENT END	1
8.	30078	SHEAR BOLT, 1/2" X 3" GRADE 2	1
9.	30022	LOCK NUT, 1/2"	1
10.	36725	COMPLETE SHIELD	1
11.	50100192	PUSH PIN AND SPRING	1

## 50100508 DRIVELINE SLIP CLUTCH

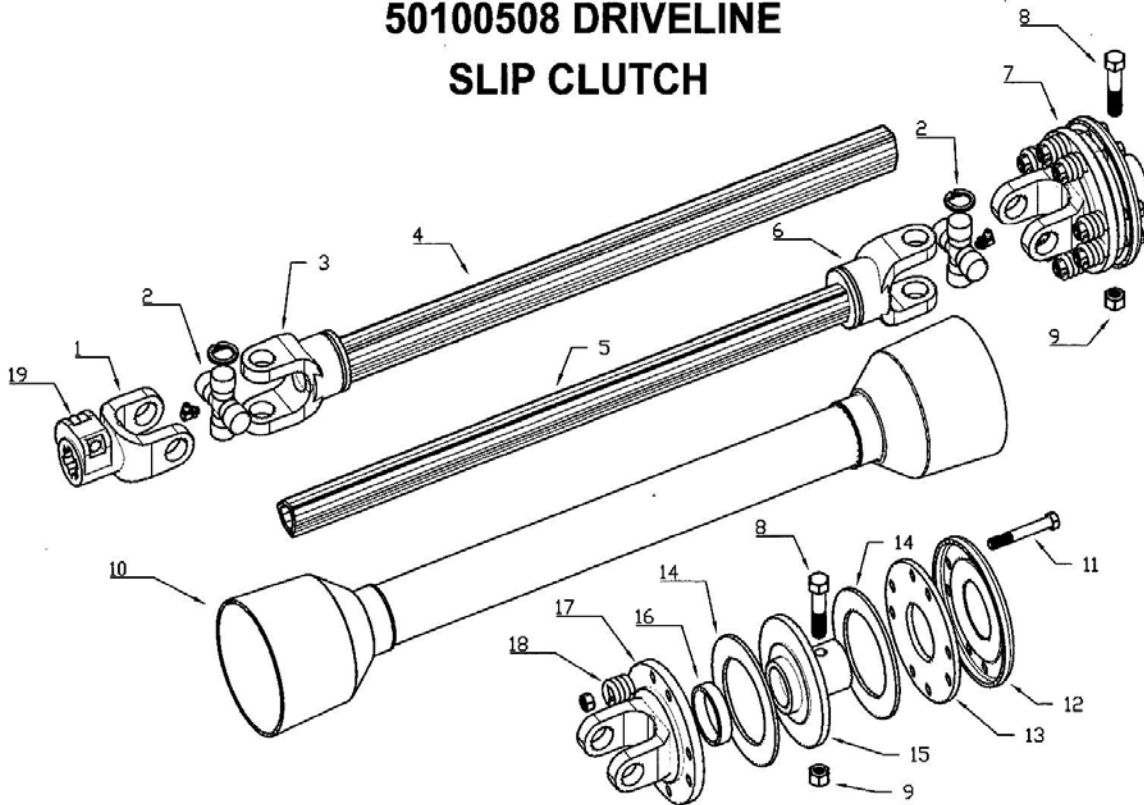

REF.	PART NO.	DESCRIPTION	QTY.
	50100508	COMPLETE DRIVELINE, SLIP CLUTCH	1
	50100526	COMPLETE TRACTOR HALF, WITH SHIELD	1
	50100528	COMPLETE IMPLEMENT HALF, WITH SHIELD	1
1.	31373	YOKE, 6 SPLINE TRACTOR END	1
2.	31370D	CROSS ASSEMBLY (CROSS, GREASE FITTING, 4 SNAP RINGS)	2
3.	31378D	YOKE	1
4.	33060D	OUTSIDE TUBE, CUT TO LENGTH	1
5.	33052D	INSIDE TUBE, CUT TO LENGTH	1
6.	31379D	YOKE	1
7.	50100529	COMPLETE SLIP CLUTCH	1
8.	10100380	BOLT 1/2 X 3, GRADE 8 (DO NOT USE FOR SHEAR PIN)	1
9.	30022	LOCK NUT, 1/2"	1
10.	36725	COMPLETE SHIELD	1
11.	50100132	BOLT, 10MM X 80 MM, & NUT	8
12.	DJ32487	PRESSURE PLATE, OUTER	1
13.	DJ32551	PRESSURE PLATE, INNER 180MM	1
14.	50100261	FRICTION DISC, 140MM (5.5"), 3-5/16" CENTER HOLE	2
15.	33910	HUB, 1-3/8" SMOOTH BORE	1
16.	50100126	SLEEVE	1
17.	DJ32491	FLANGE WITH YOKE FOR SERIES 4	1
18.	50100124	SPRING, TENSION	8
19.	50100192	PUSH PIN AND SPRING	1



# BRAVE DRIVELINE SLIP CLUTCH

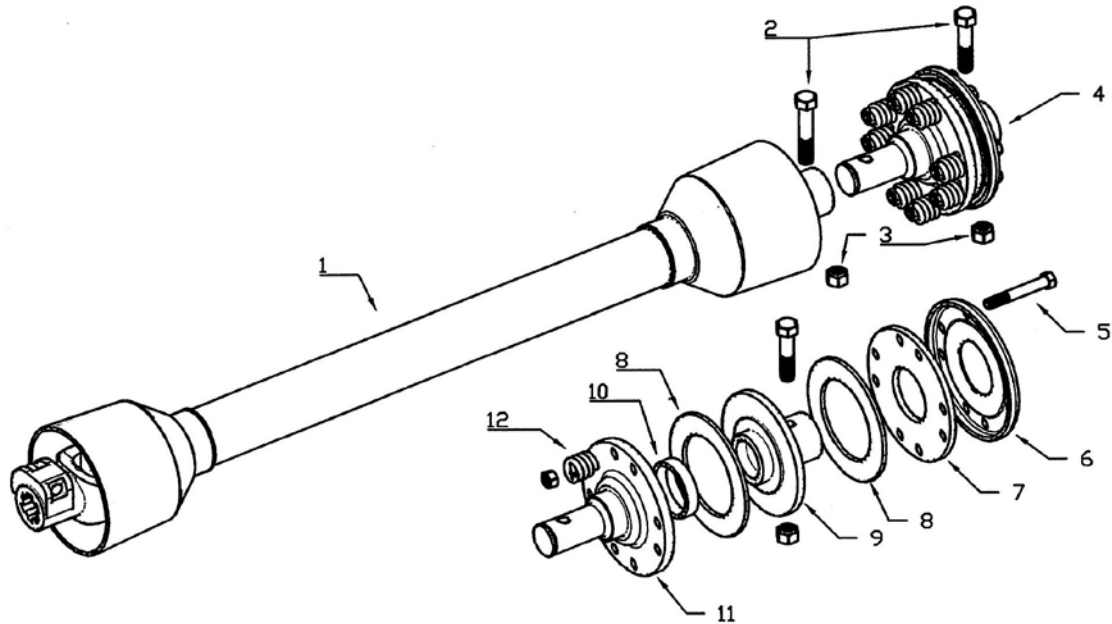

REF.	PART NO.	DESCRIPTION	QTY.
1.	50100506	COMPLETE DRIVELINE, SHEAR PIN	1
2.	10100380	BOLT 1/2 X 3, GRADE 8 (DO NOT USE FOR SHEAR PIN)	2
3.	30022	LOCK NUT, 1/2"	2
4.	33253	COMPLETE SLIP CLUTCH	1
5.	50100132	BOLT, 10MM X 80 MM, & NUT	8
6.	DJ32487	PRESSURE PLATE, OUTER	1
7.	DJ32551	PRESSURE PLATE, INNER 180MM	1
8.	50100261	FRICITION DISC, 140MM (5.5"), 3-5/16" CENTER HOLE	2
9.	33910	HUB, 1-3/8" SMOOTH BORE	1
10.	50100126	SLEEVE	1
11.	33911	FLANGE WITH 1-3/8" SMOOTH SHAFT	1
12.	50100124	SPRING, TENSION	8

# BRAVE RUBBER GUARDS

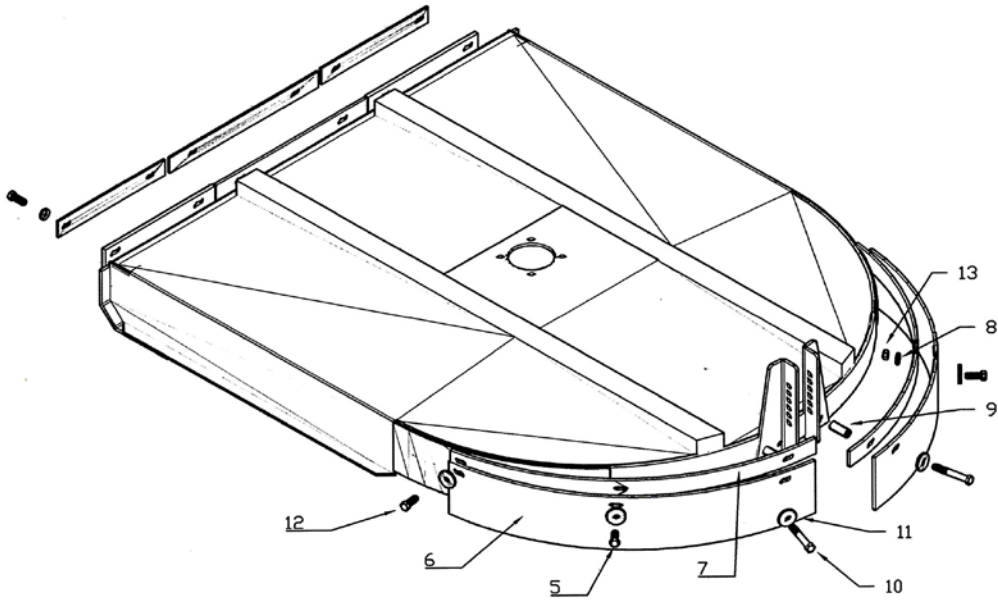
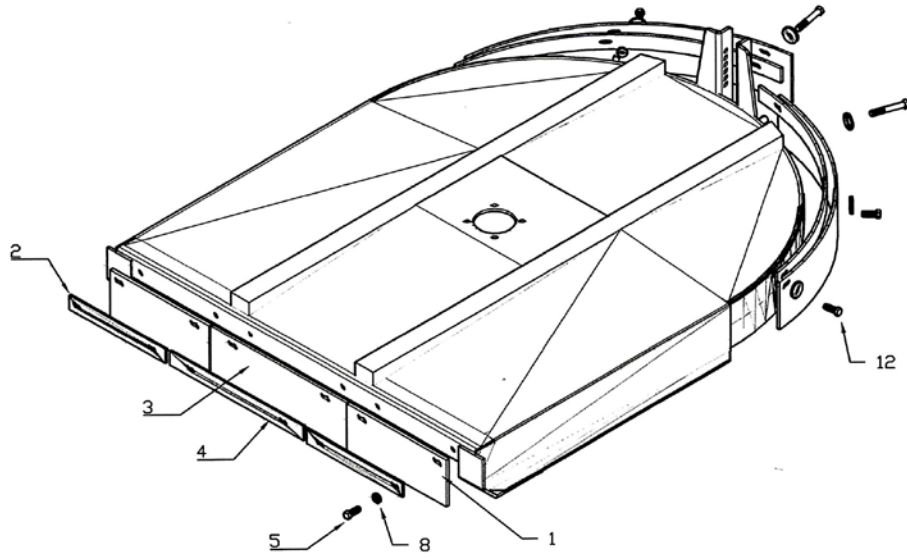

## BRAVE RUBBER GUARDS

REF.	PART NO.	DESCRIPTION	QTY.
1.	30900547	FRONT OUTER RUBBER, BRAVE 4	2
	30900545	FRONT OUTER RUBBER, BRAVE 5	2
	30900550	FRONT OUTER RUBBER, BRAVE 6	2
2.	30900532	FRONT OUTER GUARD STRIP, BRAVE 4	2
	30900531	FRONT OUTER GUARD STRIP, BRAVE 5	2
	30900529	FRONT OUTER GUARD STRIP, BRAVE 6	2
3.	30900535	FRONT CENTER RUBBER	1
4.	30900530	FRONT CENTER GUARD STRIP	1
5.	30068	HEX BOLT, 1/2" X 1-1/4"	8
6.	30900548	REAR RUBBER, BRAVE 4	2
	30900546	REAR RUBBER, BRAVE 5	2
	30900549	REAR RUBBER, BRAVE 6	2
7.	30900556	REAR RUBBER MOUNT, BRAVE 4	2
	30900543	REAR RUBBER MOUNT, BRAVE 5	2
	30900541	REAR RUBBER MOUNT, BRAVE 6	2
8.	30138	FLAT WASHER, 1/2"	10
9.	30900567	SPACER FOR REAR GUARD MOUNT	2
10.	30081	HEX BOLT, 1/2" X 4-1/2"	2
11.	33835	WASHER, 1/2" x 2" OD.(AGAINST REAR RUBBER)	6
12.	30071	HEX BOLT, 1/2" X 1-3/4"	2
13.	30022	LOCKNUT, 1/2"	12
	30900265	COMPLETE RUBBER DEFLECTORS, BRAVE 4	1
	30900580	FRONT RUBBER KIT, BRAVE 4	1
	30900581	REAR RUBBER KIT, BRAVE 4	1
	30900266	COMPLETE RUBBER DEFLECTORS, BRAVE 5	1
	30900582	FRONT RUBBER KIT, BRAVE 5	1
	30900583	REAR RUBBER KIT, BRAVE 5	1
	30900267	COMPLETE RUBBER DEFLECTORS, BRAVE 6	1
	30900584	FRONT RUBBER KIT, BRAVE 6	1
	30900585	REAR RUBBER KIT, BRAVE 6	1

# BRAVE CHAIN GUARDS

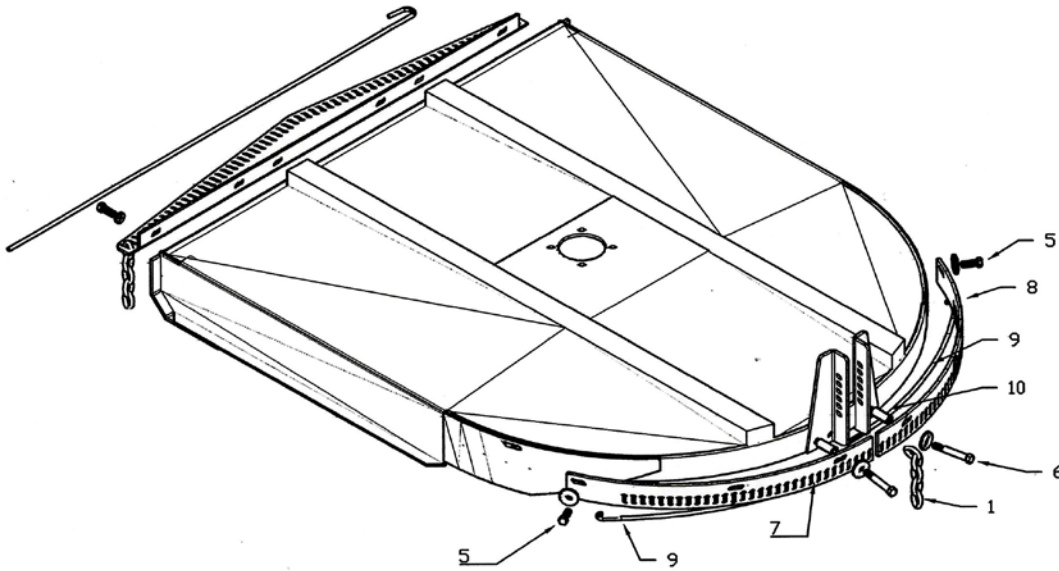
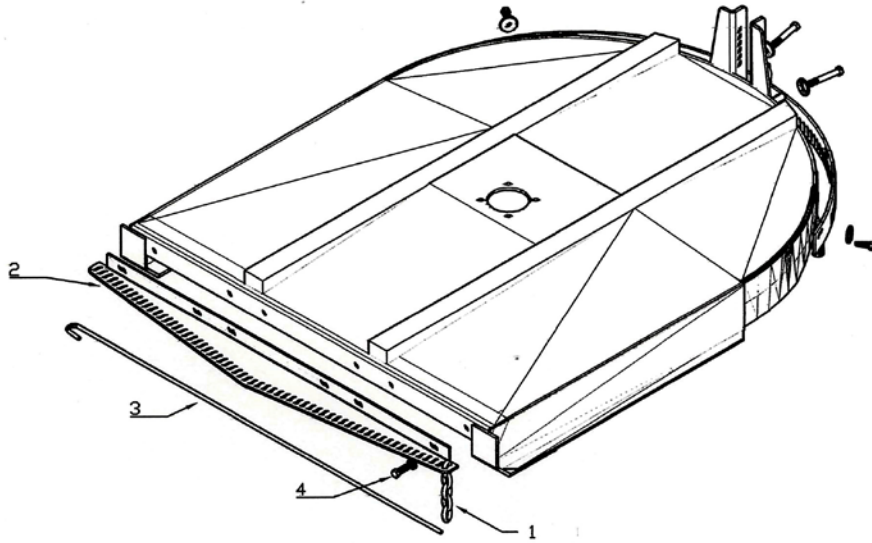

## BRAVE CHAIN GUARDS

REF.	PART NO.	DESCRIPTION	QTY.
1.	50400021	CHAIN, 5/16" X 5 LINKS	VAR
2.	30900571	FRONT CHAIN GUARD MOUNT, BRAVE 4	1
	30900570	FRONT CHAIN GUARD MOUNT, BRAVE 5	1
	30900574	FRONT CHAIN GUARD MOUNT, BRAVE 6	1
3.	30900586	FRONT CHAIN ROD, BRAVE 4	1
	30900587	FRONT CHAIN ROD, BRAVE 5	1
	30900588	FRONT CHAIN ROD, BRAVE 6	1
4.	30068	HEX BOLT, 1/2" X 1-1/4"	6
5.	30071	HEX BOLT, 1/2" X 1-3/4"	4
6.	30081	HEX BOLT, 1/2" X 4-1/2"	2
	30138	FLAT WASHER, 1/2"	10
	30022	LOCK NUT, 1/2"	10
7.	30900572	REAR CHAIN MOUNT, LEFT, BRAVE 4	1
	30900568	REAR CHAIN MOUNT, LEFT, BRAVE 5	1
	30900539	REAR CHAIN MOUNT, LEFT, BRAVE 6	1
8.	30900573	REAR CHAIN MOUNT, RIGHT, BRAVE 4	1
	30900569	REAR CHAIN MOUNT, RIGHT, BRAVE 5	1
	30900540	REAR CHAIN MOUNT, RIGHT, BRAVE 6	1
9.	30900589	REAR CHAIN ROD, BRAVE 4	2
	30900590	REAR CHAIN ROD, BRAVE 5	2
	30900591	REAR CHAIN ROD, BRAVE 6	2
10.	30900567	SPACER FOR REAR GUARD MOUNT	2
	30900592	COMPLETE CHAIN GUARD, BRAVE 4	1
	30900593	FRONT CHAIN KIT, BRAVE 4	1
	30900594	REAR CHAIN KIT, BRAVE 4	1
	30900595	COMPLETE CHAIN GUARD, BRAVE 5	1
	30900596	FRONT CHAIN KIT, BRAVE 5	1
	30900597	REAR CHAIN KIT, BRAVE 5	1
	30900598	COMPLETE CHAIN GUARD, BRAVE 6	1
	30900599	FRONT CHAIN KIT, BRAVE 6	1
	30900600	REAR CHAIN KIT, BRAVE 6	1

# BRAVE QUICK HITCH

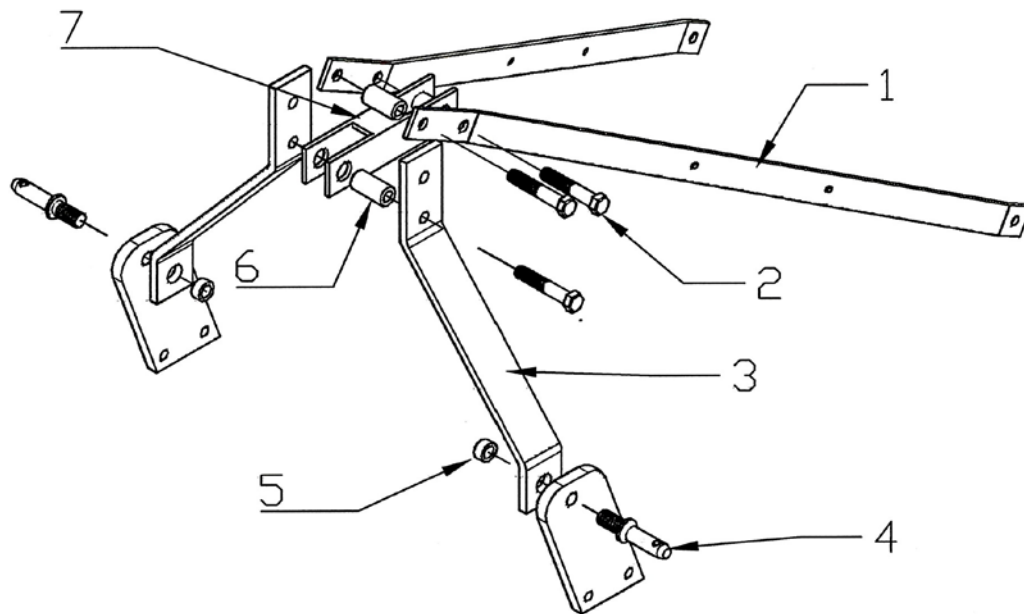

REF.	PART NO.	DESCRIPTION	QTY.
1.	30900551	REAR LINKS	2
2.	10100640	HEX BOLT, 3/4 X 4-1/2	3
	30032	LOCK NUT, 3/4"	3
3.	30900552	HITCH ARMS	2
4.	KTR-161	CAT. 1 PIN WITH NUT & LOCKWASHER	2
5.	30900555	PIVOT BUSHING FOR HITCH ARMS	2
6.	30900554	UPPER PIVOT BUSHINGS	3
7.	30900566	PIVOT LINKAGE	1

# WARRANTY

AG-MEIER INDUSTRIES LLC warrants to the original purchaser of new AG-MEIER INDUSTRIES LLC Product, that they are free for defects in material and workmanship. This warranty is applicable only for normal life expectancy of the unit or individual components for a period of one year from the date of original purchase if for personal use; 90 days for commercial or rental purposes. Warranty coverage is limited to replace any part, at no charge to the original purchaser that, in our judgment, shows evidence of defect: provided that upon written request, any such defective part is returned to AG-MEIER INDUSTRIES LLC within 30 days of failure.

This Warranty does not apply to any part or product which in AG-MEIER INDUSTRIES LLC judgment has been subjected to negligence, alteration, or modification. Equipment that has been damaged due to lack of proper maintenance or use of wrong oil or lubricants, or that has been used for a purpose for which the product is not designed is also excluded from the Warranty.

For maximum safety and to guarantee optimum product reliability, always use genuine AG-MEIER INDUSTRIES LLC parts. **The use of replacement parts manufactured by companies other than AG-MEIER INDUSTRIES LLC invalidates this Warranty.**

Claims under the warranty must be made to the dealer which originally sold the product. AG-MEIER INDUSTRIES LLC reserves the right to make changes in material or design of the product at any time without notice.

This Warranty shall not be interpreted to render AG-MEIER INDUSTRIES LLC liable for damages of any kind; direct, consequential, or contingent, to property. Furthermore, AG-MEIER INDUSTRIES LLC shall not be liable for damages resulting from any cause beyond its reasonable control. This Warranty does not extend to any expense due to loss for labor, supplies, rental machinery or for any other reason. This Warranty does not apply to any part of any internal combustion engine, driveline component, or expendable items such as blades, shields, guards, or tires as specifically found in the Operator's Manual.

Except as provided herein, no employee, agent, Dealer or other person is authorized to give any warranties of any nature on behalf of AG-MEIER INDUSTRIES LLC. This Warranty is not effective unless the Purchaser returns the Registration Form to the Manufacturer within 30 days of purchase.

No other warranty of any kind whatsoever, express or implied, is made with respect to this sale; and all implied warranties of merchantability and fitness for particular purpose which exceed the obligations set forth in this written Warranty are hereby disclaimed and excluded from this sale.

If any provision of this limited Warranty shall violate any applicable law, and is held to be unenforceable, then the invalidity of such provision shall not invalidate any other provision herein.

**BRAVE CUTTER MODEL #** \_\_\_\_\_

**BRAVE SERIAL MODEL #** \_\_\_\_\_

## Torque Values Chart for Common Bolt Sizes

Bolt Size (Inches) in-tpi <sup>1</sup>	Bolt Head Identification						Bolt Size (Metric) mm x pitch <sup>4</sup>	Bolt Head Identification					
	Grade 2		Grade 5		Grade 8			Class 5.8		Class 8.8		Class 10.9	
	N·m <sup>2</sup>	ft-lb <sup>3</sup>	N·m	ft-lb	N·m	ft-lb		N·m	ft-lb	N·m	ft-lb	N·m	ft-lb
1/4" - 20	7.4	5.6	11	8	16	12	M 5 X 0.8	4	3	6	5	9	7
1/4" - 28	8.5	6	13	10	18	14	M 6 X 1	7	5	11	8	15	11
5/16" - 18	15	11	24	17	33	25	M 8 X 1.25	17	12	26	19	36	27
5/16" - 24	17	13	26	19	37	27	M 8 X 1	18	13	28	21	39	29
3/8" - 16	27	20	42	31	59	44	M10 X 1.5	33	24	52	39	72	53
3/8" - 24	31	22	47	35	67	49	M10 X 0.75	39	29	61	45	85	62
7/16" - 14	43	32	67	49	95	70	M12 X 1.75	58	42	91	67	125	93
7/16" - 20	49	36	75	55	105	78	M12 X 1.5	60	44	95	70	130	97
1/2" - 13	66	49	105	76	145	105	M12 X 1	90	66	105	77	145	105
1/2" - 20	75	55	115	85	165	120	M14 X 2	92	68	145	105	200	150
9/16" - 12	95	70	150	110	210	155	M14 X 1.5	99	73	155	115	215	160
9/16" - 18	105	79	165	120	235	170	M16 X 2	145	105	225	165	315	230
5/8" - 11	130	97	205	150	285	210	M16 X 1.5	155	115	240	180	335	245
5/8" - 18	150	110	230	170	325	240	M18 X 2.5	195	145	310	230	405	300
3/4" - 10	235	170	360	265	510	375	M18 X 1.5	220	165	350	260	485	355
3/4" - 16	260	190	405	295	570	420	M20 X 2.5	280	205	440	325	610	450
7/8" - 9	225	165	585	430	820	605	M20 X 1.5	310	230	650	480	900	665
7/8" - 14	250	185	640	475	905	670	M24 X 3	480	355	760	560	1050	780
1" - 8	340	250	875	645	1230	910	M24 X 2	525	390	830	610	1150	845
1" - 12	370	275	955	705	1350	995	M30 X 3.5	960	705	1510	1120	2100	1550
1-1/8" - 7	480	355	1080	795	1750	1290	M30 X 2	1060	785	1680	1240	2320	1710
1 1/8" - 12	540	395	1210	890	1960	1440	M36 X 3.5	1730	1270	2650	1950	3660	2700
1 1/4" - 7	680	500	1520	1120	2460	1820	M36 X 2	1880	1380	2960	2190	4100	3220
1 1/4" - 12	750	555	1680	1240	2730	2010							
1 3/8" - 6	890	655	1990	1470	3230	2380							
1 3/8" - 12	1010	745	2270	1670	3680	2710							
1 1/2" - 6	1180	870	2640	1950	4290	3160							
1 1/2" - 12	1330	980	2970	2190	4820	3560							

<sup>1</sup> in-tpi = nominal thread dia. in inches-threads per inch

<sup>2</sup> N·m = newton-meters

<sup>3</sup> ft-lb= foot pounds

<sup>4</sup> mm x pitch = nominal thread dia. in millimeters x thread pitch

Torque tolerance + 0%, -15% of torquing values. Unless otherwise specified use torque values listed above.

**Blade Bolt Nut**  
**Blade Carrier Hub Nut**

600 ft-lbs  
450 ft-lbs Minimum



# WARRANTY REGISTRATION FORM & INSPECTION REPORT

## WARRANTY REGISTRATION

This form must be filled out by the dealer and signed by both the dealer and the customer at time of delivery.

Customer name \_\_\_\_\_ Dealer name \_\_\_\_\_  
Address \_\_\_\_\_ Address \_\_\_\_\_  
City, state, code \_\_\_\_\_ City, state, code \_\_\_\_\_  
Phone number (\_\_\_\_\_) \_\_\_\_\_  
Model \_\_\_\_\_ Serial Number \_\_\_\_\_ Delivery date \_\_\_\_\_

DEALER: I hereby certify that:

I have thoroughly instructed the buyer on the above-described equipment; review including the operator's manual content, equipment care, adjustments, safe operation and applicable warranty policy.

All decals are installed and are in good repair.

Driveline, gearbox, and shields are in good repair and fastened securely in place to prevent injuries from entanglement or thrown objects.

All bolts have been checked and tightened.

Date \_\_\_\_\_ Dealer's signature \_\_\_\_\_

The above equipment and operators manual have been received by me, and I have been thoroughly instructed as to the care, adjustments, safe operation and applicable warranty policy

I have examined the equipment and accept it in complete and satisfactory condition

I have also examined all the warning/safety decals and understand the dangers of unauthorized repairs and alterations of the product

I further understand that attempting to operate this product outside of the specified design parameter will void the warranty as stated in the operating manual

I also understand that this warranty is considered null and void if I use any replacement parts other than those approved by AG-MEIER IND.

All warranty work **MUST BE APPROVED** by AG-MEIER IND. **BEFORE** any replacement or labor costs will be reimbursed.

Date \_\_\_\_\_ Owner's signature \_\_\_\_\_

**AG-MEIER INDUSTRIES, LLC  
920 E. 6<sup>TH</sup> AVE.  
BELTON, TX 76513**