

# UNVENTED (VENT-FREE) INFRARED GAS HEATER SAFETY INFORMATION AND INSTALLATION MANUAL

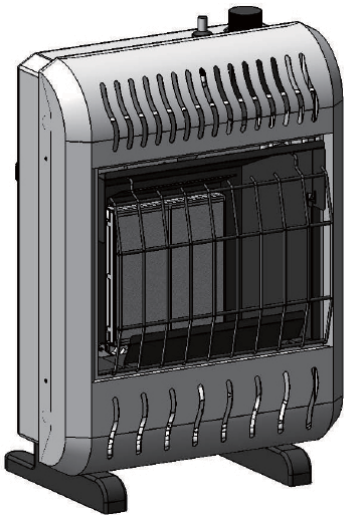

**Model: IWH10NLTB**

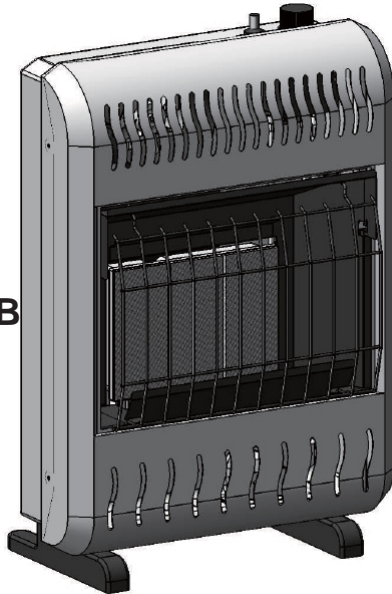

**Model: IWH16NLTB**

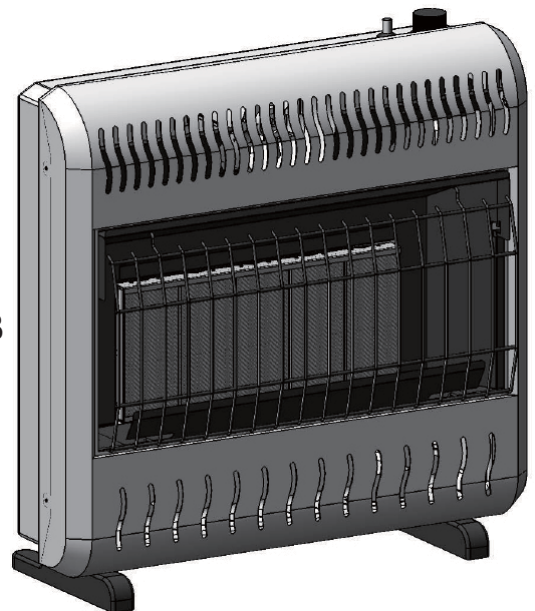

**Model: IWH26NLTB**



**WARNING:** If the information in this manual is not followed exactly, a fire or explosion may result causing property damage, personal injury or loss of life.

- Do not store or use gasoline or other flammable vapors and liquids in the vicinity of this or any other appliance.
- **WHAT TO DO IF YOU SMELL GAS**
  - Do not try to light any appliance.
  - Do not touch any electrical switch; do not use any phone in your building.
  - Immediately call your gas supplier from a neighbor's phone. Follow the gas supplier's instructions.
  - If you cannot reach your gas supplier, call the fire department.
- Installation and service must be performed by a qualified installer, service agency or the gas supplier.

**INSTALLER:** Leave this manual with the appliance.

**CONSUMER:** Retain this manual for future reference.

---

## TABLE OF CONTENTS

Safety Information .....	2	Cleaning and Maintenance .....	20
Local Codes.....	4	Troubleshooting.....	21
Product Identification .....	4	Specifications .....	24
Unpacking.....	4	Wiring Diagrams .....	24
Product Features.....	4	Service Hints .....	24
Air For Combustion and Ventilation .....	5	Replacement Parts .....	24
Installation.....	7	Technical Service.....	28
Operating Heater .....	17	Service Publications .....	28
Inspecting Heater .....	19	Warranty Information .....	Back Cover

## SAFETY INFORMATION

**WARNING: Improper installation, adjustment, alteration, service or maintenance can cause injury or property damage. Refer to this manual for correct installation and operational procedures. For assistance or additional information consult a qualified installer service agency or the gas supplier.**

**WARNING: This is an unvented gas fired heater. It uses air (oxygen) from the room in which it is installed. Provisions for adequate combustion and ventilation air must be provided. Refer to Air for Combustion and Ventilation section on page 5 of this manual.**

**This appliance is only for use with the type of gas indicated on the rating plate. This appliance is not convertible for use with other gases.**

**This appliance may be installed in an aftermarket,\*permanently located, manufactured (mobile) home, where not prohibited by local codes.**

\* Aftermarket: Completion of sale, not for purpose of resale, from the manufacturer

**WARNING: This product contains and/or generates chemicals known to the State of California to cause cancer or birth defects or other reproductive harm.**

**IMPORTANT: Read this owner's manual carefully and completely before trying to assemble, operate or service this heater. Improper use of this heater can cause serious injury or death from burns, fire, explosion, electrical shock and carbon monoxide poisoning.**

# SAFETY INFORMATION

*Continued*

 **DANGER: Carbon monoxide poisoning may lead to death!**

**Carbon Monoxide Poisoning:** Early signs of carbon monoxide poisoning resemble the flu, with headaches, dizziness or nausea. If you have these signs, the heater may not be working properly. Get fresh air at once! Have heater serviced. Some people are more affected by carbon monoxide than others. These include pregnant women, people with heart or lung disease or anemia, those under the influence of alcohol and those at high altitudes.

**Natural and Propane/LP Gas:** Natural and Propane/LP gases are odorless. An odor-making agent is added to these gases. The odor helps you detect a gas leak. However, the odor added to the gas can fade. Gas may be present even though no odor exists. Make certain you read and understand all warnings. Keep this manual for reference. It is your guide to safe and proper operation of this heater.

 **WARNING: Any change to this heater or its controls can be dangerous.**

 **WARNING: Do not use a blower insert, heat exchanger insert or other accessory not approved for use with this heater.**

**Due to high temperatures, the appliance should be located out of traffic and away from furniture and draperies.**

**Do not place clothing or other flammable material on or near the appliance. Never place any objects on the heater.**

**Keep the appliance area clear and free from combustible materials, gasoline and other flammable vapors and liquids.**

**Surface of heater becomes very hot when running heater. Keep children and adults away from hot surface to avoid burns or clothing ignition. Heater will remain hot for a time after shutdown. Allow surface to cool before touching.**

**Carefully supervise young children when they are in the same room with heater.**

**Make sure grill guard is in place before running heater.**

1. This appliance is only for use with the type of gas indicated on the rating plate. This appliance is not convertible for use with other gases.
2. Do not place propane/LP supply tank(s) inside any structure. Locate propane/LP supply tank(s) outdoors.
3. For room heater having an input rating in excess of 6000 BTU/hr (1758W), this heater shall not be installed in a bathroom. For room heater having an input rating in excess of 10,000 BTU/hr (2931W), this heater shall not be installed in a bedroom or bathroom.
4. If you smell gas
  - shut off gas supply
  - do not try to light any appliance
  - do not touch any electrical switch; do not use any phone in your building
  - immediately call your gas supplier from a neighbor's phone. Follow the gas supplier's instructions
  - if you cannot reach your gas supplier, call the fire department
5. This heater needs fresh, outside air ventilation to run properly. This heater has an Oxygen Depletion Sensing (ODS) safety shutoff system. The ODS shuts down the heater if not enough fresh air is available. See Air for Combustion and Ventilation, page 5.
6. Keep all air openings in front and bottom of heater clear and free of debris. This will ensure enough air for proper combustion.
7. If heater shuts off, do not relight until you provide fresh, outside air. If heater keeps shutting off, have it serviced.

## SAFETY INFORMATION

*Continued*

8. If heater shuts off, do not relight until you provide fresh, outside air. If heater keeps shutting off, have it serviced.
9. Do not run heater
  - where flammable liquids or vapors are used or stored
  - under dusty conditions
10. Do not use heater if any part has been under water. Call a qualified service technician immediately to inspect the room heater. If necessary, replace some parts of the control system and some parts of the gas control which has been under water.
11. Turn off and unplug heater and let cool before servicing. Only a qualified service person should service and repair heater.
12. Operating heater above elevations of 4,500 feet (1,371 m) could cause pilot outage.
13. To prevent performance problems, do not use propane/LP fuel tank of less than 100 lbs. (45 kg) capacity.
14. Before using furniture polish, wax, carpet cleaner or similar products, turn heater off. If heated, the vapors from these products may create a white powder residue within burner box or on adjacent walls or furniture.
15. Provide adequate clearances around air openings.

## LOCAL CODES

Install and use heater with care. Follow all local codes. In the absence of local codes, use the latest edition of The National Fuel Gas Code, ANSI Z223.1/NFPA 54\*.

\*Available from:

American National Standards Institute, Inc.  
1430 Broadway  
New York, NY 10018  
National Fire Protection Association, Inc.  
Batterymarch Park  
Quincy, MA 02269

**State of Massachusetts:** The installation must be made by a licensed plumber or gas fitter in the Commonwealth of Massachusetts. Sellers of unvented propane or natural gas-fired supplemental room heaters shall provide to each purchaser a copy of 527 CMR 30 upon sale of the unit.

Vent-free gas products are prohibited for bedroom and bathroom installation in the Commonwealth of Massachusetts.

## PRODUCT IDENTIFICATION

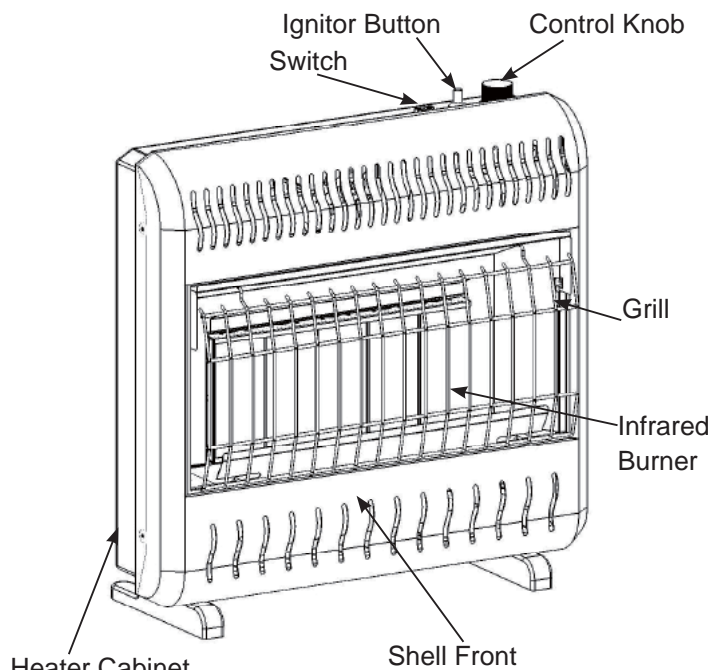

**Figure 1 - Vent-Free Gas Heater**

## UNPACKING

1. Remove heater from carton.
2. Remove all protective packaging applied to heater for shipment.
3. Check heater for any shipping damage. If heater is damaged, promptly return to where you bought heater.

## PRODUCT FEATURES

### SAFETY DEVICE

This heater has a pilot with an Oxygen Depletion Sensing (ODS) safety shutoff system. The ODS/pilot is a required feature for vent-free room heaters. The ODS/pilot shuts off the heater if there is not enough fresh air.

### PIEZO IGNITION SYSTEM

This heater has a piezo ignitor. This system requires no matches, batteries or other sources to light heater

### THERMOSTATIC HEAT CONTROL

Thermostat models have a thermostat sensing bulb and a control valve. This results in the greatest heater comfort. This can also result in lower gas bills.



---

# AIR FOR COMBUSTION AND VENTILATION

 **WARNING: This heater shall not be installed in a confined space or unusually tight construction unless provisions are provided for adequate combustion and ventilation air. Read the following instructions to ensure proper fresh air for this and other fuel-burning appliances in your home.**

Today's homes are built more energy efficient than ever. New materials, increased insulation and new construction methods help reduce heat loss in homes. Home owners weather strip and caulk around windows and doors to keep the cold air out and the warm air in. During heating months, home owners want their homes as airtight as possible.

While it is good to make your home energy efficient, your home needs to breathe. Fresh air must enter your home. All fuel-burning appliances need fresh air for proper combustion and ventilation.

Exhaust fans, fireplaces, clothes dryers and fuel burning appliances draw air from the house to operate. You must provide adequate fresh air for these appliances. This will ensure proper venting of vented fuel-burning appliances.

## PROVIDING ADEQUATE VENTILATION

The following are excerpts from National Fuel

Gas Code, ANSI Z223.1/NFPA 54, Section 5.3, Air for Combustion and Ventilation.

All spaces in homes fall into one of the three following ventilation classifications:

1. Unusually Tight Construction
2. Unconfined Space
3. Confined Space

The information on pages 5 through 7 will help you classify your space and provide adequate ventilation.

## Unusually Tight Construction

The air that leaks around doors and windows may provide enough fresh air for combustion and ventilation. However, in buildings of unusually tight construction, you must provide additional fresh air.

Unusually tight construction is defined as construction where:

- a. walls and ceilings exposed to the outside atmosphere have a continuous water vapor retarder with a rating of one perm (6 x 10<sup>-11</sup> kg per pa-sec-m ) or less with openings gasketed or sealed and
- b. weather stripping has been added on openable windows and doors and
- c. caulking or sealants are applied to areas such as joints around window and door frames, between sole plates and floors, between wall-ceiling joints, between wall panels, at penetrations for plumbing, electrical and gas lines and at other openings.

If your home meets all of these three criteria, you must provide additional fresh air. See Ventilation Air From Outdoors, page 7.

If your home does not meet all of the three criteria above, proceed to Determining Fresh-Air Flow For Heater Location, page 6.

## Confined and Unconfined Space

The National Fuel Gas Code, ANSI Z223.1/NFPA 54 defines a confined space as a space whose volume is less than 50 cubic feet per 1,000 Btu per hour (4.8 m<sup>3</sup> per kw) of the aggregate input rating of all appliances installed in that space and an unconfined space as a space whose volume is not less than 50 cubic feet per 1,000 Btu per hour (4.8 m<sup>3</sup> per kw) of the aggregate input rating of all appliances installed in that space. Rooms communicating directly with the space in which the appliances are installed\*, through openings not furnished with doors, are considered a part of the unconfined space.

\* Adjoining rooms are communicating only if there are doorless passageways or ventilation grills between them.

# AIR FOR COMBUSTION AND VENTILATION

*Continued*

## DETERMINING FRESH-AIR FLOW FOR HEATER LOCATION

### Determining if you Have a Confined or Unconfined Space

Use this work sheet to determine if you have a confined or unconfined space.

**Space:** Includes the room in which you will install heater plus any adjoining rooms with doorless passageways or ventilation grills between the rooms.

1. Determine the volume of the space (length x width x height).

Length x Width x Height = \_\_\_\_\_ cu. ft. (volume of space)

Example: Space size 20 ft. (6.1 m) (length) x 16 ft. (4.88 m) (width) x 8 ft. (2.44 m) (ceiling height) = 2560 cu. ft. (72.49 m<sup>3</sup>) (volume of space)

If additional ventilation to adjoining room is supplied with grills or openings, add the volume of these rooms to the total volume of the space.

2. Multiply the space volume by 20 to determine

the maximum Btu/Hr the space can support.  
 \_\_\_\_\_ (volume of space) x 20 = (Maximum Btu/Hr the space can support)

Example: 2560 cu. ft. (72.49 m<sup>3</sup>) (volume of space) x 20 = 51,200 (maximum Btu/Hr the space can support)

3. Add the Btu/Hr of all fuel burning appliances in the space.

Vent-free heater \_\_\_\_\_ Btu/Hr  
 Gas water heater\* \_\_\_\_\_ Btu/Hr  
 Gas furnace \_\_\_\_\_ Btu/Hr  
 Vented gas heater \_\_\_\_\_ Btu/Hr  
 Gas fireplace logs \_\_\_\_\_ Btu/Hr  
 Other gas appliances\* + \_\_\_\_\_ Btu/Hr  
 Total = \_\_\_\_\_ Btu/Hr

\* Do not include direct-vent gas appliances. Direct-vent draws combustion air from the outdoors and vents to the outdoors.

Example:

Gas water heater 40,000 Btu/Hr  
 Vent-free heater + 20,000 Btu/Hr  
 Total = 60,000 Btu/Hr

4. Compare the maximum Btu/Hr the space can support with the actual amount of Btu/Hr used.

\_\_\_\_\_ Btu/Hr (maximum can support)

\_\_\_\_\_ Btu/Hr (actual amount)

Example: 51,200 Btu/Hr (maximum the space can support)  
 60,000 Btu/Hr (actual amount of Btu/Hr used)

The space in the above example is a confined space because the actual Btu/Hr used is more than the maximum Btu/Hr the space can support. You must provide additional fresh air. Your options are as follows:

- Rework worksheet, adding the space of an adjoining room. If the extra space provides an unconfined space, remove door to adjoining room or add ventilation grills between rooms. See Ventilation Air From Inside Building, page 7.
- Vent room directly to the outdoors. See Ventilation Air From Outdoors, page 7.
- Install a lower Btu/Hr heater, if lower Btu/Hr size makes room unconfined.

If the actual Btu/Hr used is less than the maximum Btu/Hr the space can support, the space is an unconfined space. You will need no additional fresh air ventilation.

 **WARNING: If the area in which the heater may be operated is smaller than that defined as an unconfined space or if the building is of unusually tight construction, provide adequate combustion and ventilation air by one of the methods described in the National Fuel Gas Code, ANSI Z223.1/ NFPA 54 Section 5.3 or applicable local codes.**

## VENTILATION AIR

### Ventilation Air From Inside Building

This fresh air would come from an adjoining unconfined space. When ventilating to an adjoining unconfined space, you must provide two permanent openings: one within 12" ( 0.5 cm) of the ceiling and one within 12" (30.5 cm) of the floor on the wall connecting the two spaces (see options 1 and 2, Figure 2, page 7). You can also remove door into adjoining room (see option 3, Figure 2, page 7). Follow the National Fuel Gas Code, ANSI Z223.1/NFPA 54, Section 5.3, Air for Combustion and Ventilation for required size of ventilation grills or ducts.

# AIR FOR COMBUSTION AND VENTILATION

*Continued*

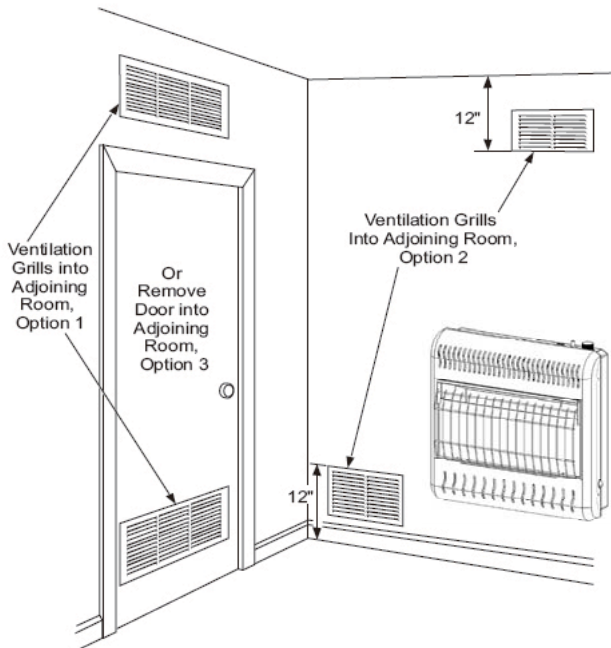
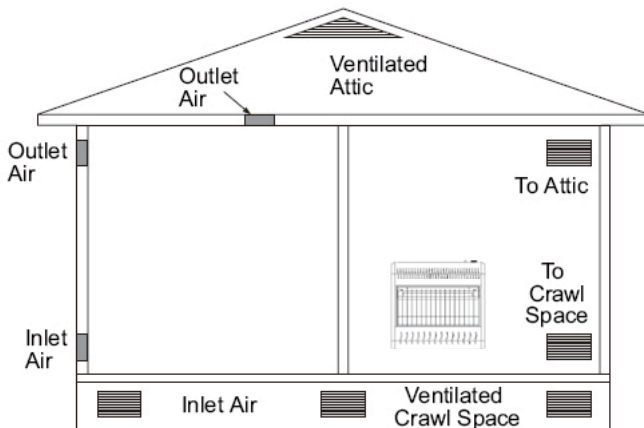

**Figure 2 - Ventilation Air from Inside Building**

## Ventilation Air From Outdoors

Provide extra fresh air by using ventilation grills or ducts. You must provide two permanent openings: one within 1" (0.5 cm) of the ceiling and one within 1" (0.5 cm) of the floor. Connect these items directly to the outdoors or spaces open to the outdoors. These spaces include attics and crawl spaces. Follow the National Fuel Gas Code, ANSI Z223.1/NFPA 54, Section 5.3, Air for Combustion and Ventilation for required size of ventilation grills or ducts.

**IMPORTANT:** Do not provide openings for inlet or outlet air into attic if attic has a thermostat-controlled power vent. Heated air entering the attic will activate the power vent.



**Figure 3 - Ventilation Air from Outdoor**

# INSTALLATION

**NOTICE:** This heater is intended for use as supplemental heat. Use this heater along with your primary heating system. Do not install this heater as your primary heat source. If you have a central heating system, you may run system's circulating blower while using heater. This will help circulate the heat throughout the house. In the event of a power outage, you can use this heater as your primary heat source.

**WARNING:** A qualified service person must install heater. Follow all local codes.

## CHECK GAS TYPE

Use only the correct type of gas (natural or propane/LP). If your gas supply is not the correct gas type, do not install heater. Call dealer where you bought heater for proper type heater.

**WARNING:** This appliance is equipped for either natural gas or propane/LP gas but not both. Gas type is indicated on the rating plate. Field conversion is not permitted.

# INSTALLATION

*Continued*

## INSTALLATION ITEMS

Before installing heater, make sure you have the items listed below.

- for propane/LP gas, external regulator (supplied by installer)
- piping (check local codes)
- sealant (resistant to propane/LP gas)
- equipment shutoff valve \*
- ground joint union
- sediment trap
- tee joint
- pipe wrench
- for natural gas, test gauge connection\*
- hardware packet
  - wall anchor (4)
  - key (1)
  - Mounting screw, black (4)
  - nylon spacer (2)
  - Sheet metal screw, silver (4)

\* An CSA design-certified equipment shutoff valve with 1/8" NPT tap is an acceptable alternative to test gauge connection. The optional CSA design-certified equipment shutoff valve can be purchased from your dealer.

## LOCATING HEATER

This heater is designed to be mounted on a wall.

**WARNING:** Maintain the minimum clearances shown in Figure 4. If you can, provide greater clearances from floor, ceiling and joining wall.

You can locate heater on floor, away from a wall. An optional floor mounting stand is included.

- WARNING:** Never install the heater
- in a bathroom for room heater having an input rating in excess of 6000 BTU/hr; in a bedroom or bathroom for room heater having an input rating in excess of 10,000 BTU/hr.
  - in a recreational vehicle
  - where curtains, furniture, clothing or other flammable objects are less than 36" (91.5 cm) from the front, top or sides of the heater
  - as a fireplace insert
  - in high traffic areas
  - in windy or drafty areas

**CAUTION:** If you install the heater in a home garage

- heater pilot and burner must be at least 18" (45.7 cm) above floor
- locate heater where moving vehicle will not hit it

**CAUTION:** This heater creates warm air currents. These currents move heat to wall surfaces next to heater. Installing heater next to vinyl or cloth wall coverings or operating heater where impurities (such as, but not limited to, tobacco smoke, aromatic candles, cleaning fluids, oil or kerosene lamps, etc.) in the air exist, may discolor walls or cause odors.

*IMPORTANT:* Vent-free heaters add moisture to the air. Although this is beneficial, installing heater in rooms without enough ventilation air may cause mildew to form from too much moisture. See Air for Combustion and Ventilation, page 5. If high humidity is experienced, a dehumidifier may be used to help lower the water vapor content in the air. For convenience and efficiency, install heater

- where there is easy access for operation, inspection and service
- in coldest part of room

To use fan, locate heater near an electrical outlet.

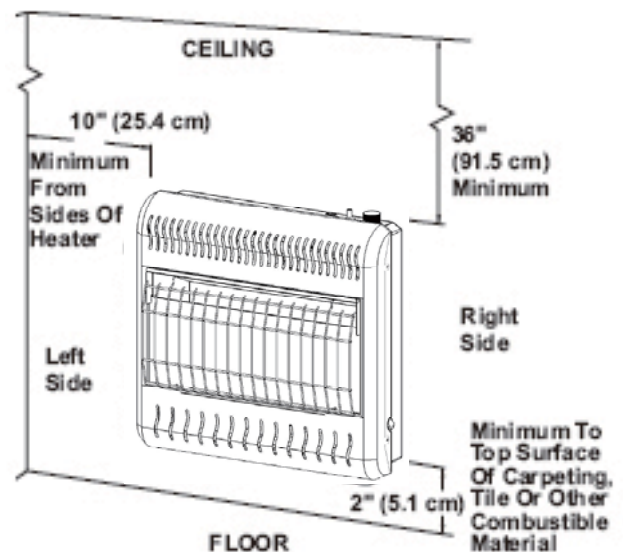

*Figure 4 - Mounting Clearances As Viewed From Front of Heater*



# INSTALLATION

*Continued*

## INSTALLING HEATER TO WALL

### Mounting Bracket

Locate mounting bracket in heater carton. Remove mounting bracket from heater carton.



**Figure 5 - Mounting Bracket**

### Removing Shell Front Of Heater

1. Remove the four painted screws, two on each side of shell front.
2. Pull bottom of shell front 14" (35.6 cm) out.
3. Remove any remaining packaging materials.

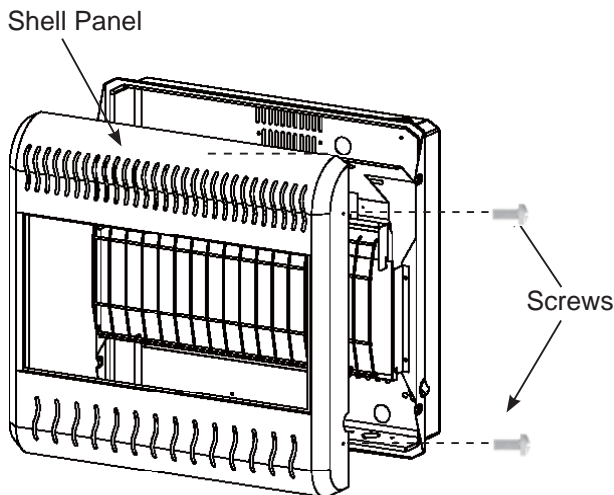

**Figure 6 - Removing Shell Front Of Heater**

### Methods For Attaching Mounting Bracket To Wall

Only use last hole on each end of mounting bracket to attach bracket to wall. Attach mounting bracket to wall in one of two ways:

1. Attaching to wall stud
2. Attaching to wall anchor

**Attaching to Wall Stud:** This method provides the strongest hold. Insert mounting screws through mounting bracket and into wall studs.

**Attaching to Wall Anchor:** This method allows you to attach mounting bracket to hollow walls (wall areas between studs) or to solid walls (concrete or masonry).

Decide which method better suits your needs. Either method will provide a secure hold for the mounting bracket.

### Marking Screw Locations

1. Tape mounting bracket to wall where heater will be located. Make sure mounting bracket is level.

**! WARNING: Maintain minimum clearances shown in Figure 8. If you can, provide greater clearances from floor and joining wall.**

2. Mark screw locations on wall (see Figure 7).  
Note: Only mark last hole on each end of mounting bracket. Insert mounting screws through these holes only.
3. Remove tape and mounting bracket from wall.

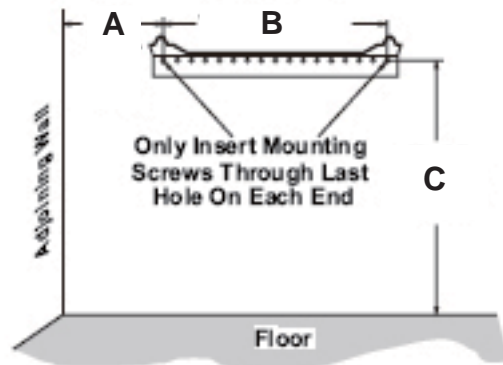

**Figure 7 - Mounting Bracket Clearances**

ITEM NO.	IWH10	IWH16	IWH26
A	8"	12"	16"
B	11"	14"	14"
C	18 3/4"	19 3/4"	19 3/4"

# INSTALLATION

## Continued

### Attaching To Wall Stud Method

For attaching mounting bracket to wall studs

1. Drill holes at marked locations using 9/64" drill bit.
2. Place mounting bracket onto wall. Line last hole on each end of bracket with holes drilled in wall.
3. Insert mounting screws through bracket and into wall studs.
4. Tighten screws until mounting bracket is firmly fastened to wall studs.

### Attaching To Wall Anchor Method

For attaching mounting bracket to hollow walls (wall areas between studs) or solid walls (concrete or masonry)

1. Drill holes at marked locations using 5/16" drill bit. For solid walls (concrete or masonry), drill at least 1" (2.5 cm) deep.
2. Fold wall anchor as shown in Figure 10.
3. Insert wall anchor (wings first) into hole. Lightly tap anchor flush to wall.
4. For thin walls [1/2" (1.3 cm) or less], insert red key into wall anchor. Push red key to "pop" open anchor wings.  
*IMPORTANT:* Do not hammer key! For thick walls [over 1/2" (1.3 cm) thick] or solid walls, do not pop open wings.
5. Place mounting bracket onto wall. Line up last hole on each end of bracket with wall anchors.
6. Insert mounting screws through bracket and into wall anchors.
7. Tighten screws until mounting bracket is firmly fastened to wall.

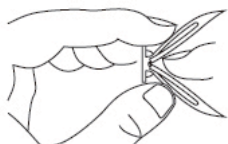

**Figure 8 - Folding Anchor**

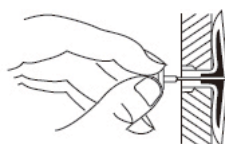

**Figure 9 - Popping Open Anchor Wings For Thin Walls**

### Placing Heater On Mounting Bracket

1. Locate two horizontal slots on back panel of heater.
2. Place heater onto mounting bracket. Slide horizontal slots onto stand-out tabs on mounting bracket.

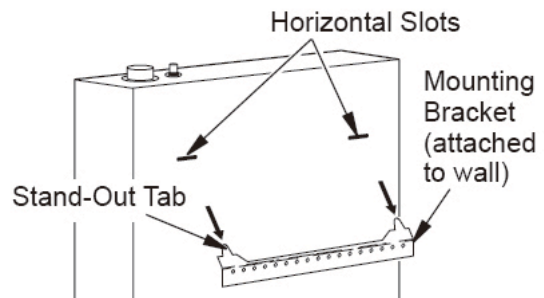

**Figure 10 - Mounting Heater Onto Mounting Bracket**

### Installing Bottom Mounting Screws

1. Locate two bottom mounting holes. These holes are near bottom on back panel of heater (see Figure 11 ).
2. Mark screw locations on wall.
3. Remove heater from mounting bracket.
4. If installing bottom mounting screws into hollow or solid wall, install wall anchors. Follow steps 1 through 4 under Attaching To Wall Anchor Method.  
If installing bottom mounting screw into wall stud, drill holes at marked locations using 9/64" drill bit.
5. Replace heater onto mounting bracket.
6. Place spacers between bottom mounting holes and wall anchor or drilled hole.
7. Hold spacer in place with one hand. With other hand, insert mounting screw through bottom mounting hole and spacer. Place tip of screw in opening of wall anchor or drilled hole.
8. Tighten both screws until heater is firmly secured to wall. Do not over tighten.  
Note: Do not replace front panel at this time. Replace front panel after making gas connections and checking for leaks (see page 11-15).

## INSTALLATION

*Continued*

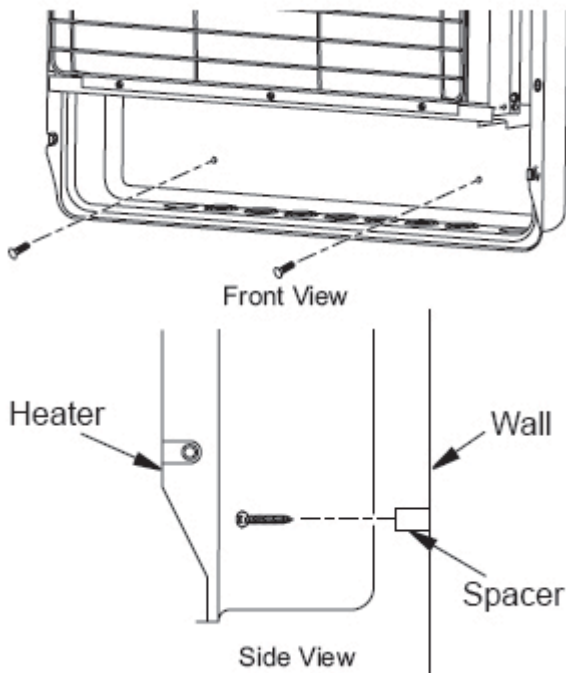

**Figure 11 - Installing Bottom Mounting Screws**

### MOUNTING HEATER TO FLOOR WITH OPTIONAL FLOOR KIT

#### Mounting Base Feet to Heater

Note: A 90° elbow is required for mounting this unit and must be installed BEFORE base feet to provide proper clearance (see Figure 14, page 12).

1. Lay heater cabinet on its back on a table with the heater bottom overhanging table edge.
2. Apply pipe joint sealant lightly to male NPT threads of elbow. Connect the elbow to the pressure regulator with a wrench. Do not overtighten elbow to regulator. Regulator body could be damaged.
3. Align holes in base feet with mounting holes on bottom of cabinet (see Figure 12).
4. Secure base feet to heater using sheet metal screws.

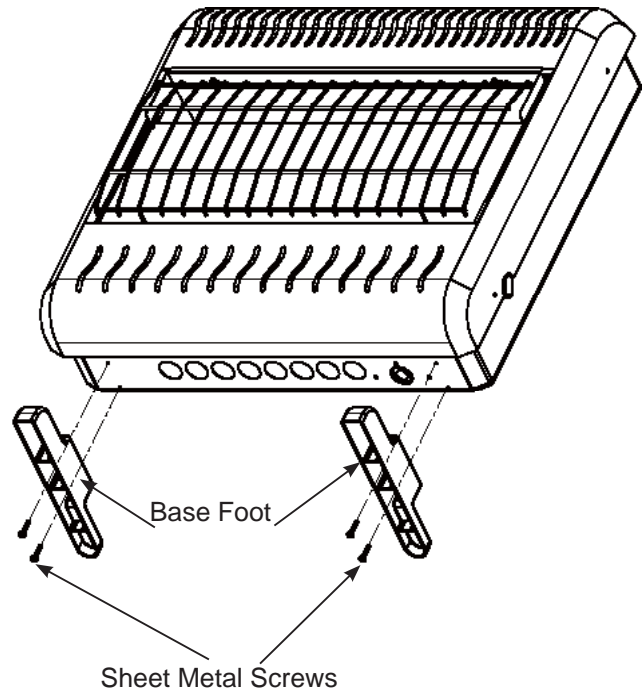

**Figure 12 - Installing Base Feet**

### CONNECTING TO GAS SUPPLY

**⚠ WARNING:** This appliance requires a 3/8" NPT (National Pipe Thread) inlet connection to the pressure regulator.

**⚠ WARNING:** A qualified service person must connect heater to gas supply. Follow all local codes.

**⚠ WARNING:** For natural gas, never connect heater to private (non-utility) gas wells. This gas is commonly known as wellhead gas.

**IMPORTANT:** For natural gas, check gas line pressure before connecting heater to gas line. Gas line pressure must be no greater than 10.5" of water. If gas line pressure is higher, heater regulator damage could occur.

**⚠ CAUTION:** For propane/LP gas, never connect heater directly to the propane/LP supply. This heater requires an external regulator (not supplied). Install the external regulator between the heater and propane/LP supply.

# INSTALLATION

## Continued

For propane/LP gas, the installer must supply an external regulator. The external regulator will reduce incoming gas pressure. You must reduce incoming gas pressure to between 11" and 14" of water. If you do not reduce incoming gas pressure, heater regulator damage could occur. Install the external regulator with the vent pointing down as shown in Figure 14. Pointing the vent down protects it from freezing rain or sleet.

**CAUTION:** Use only new, black iron or steel pipe. Internally-tinned copper tubing may be used in certain areas. Check your local codes. Use pipe of large enough diameter to allow proper gas volume to heater. If pipe is too small, undue loss of volume will occur.

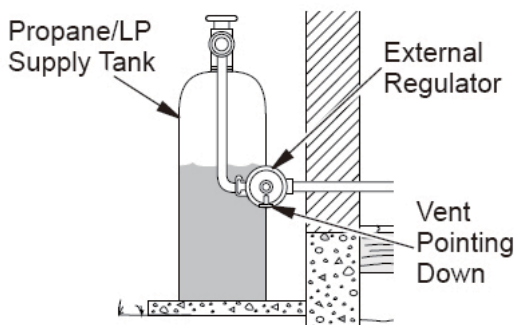

**Figure 13 - External Regulator With Vent Pointing Down**

### Typical Inlet Pipe Diameters - 3/8" or greater

Installation must include equipment shutoff valve, union and plugged 1/8" NPT tap. Locate NPT tap within reach for test gauge hook up. NPT tap must be upstream from heater (see Figure 14).

**IMPORTANT:** Install an equipment shutoff valve in an accessible location. The equipment shutoff valve is for turning on or shutting off the gas to the appliance.

Apply pipe joint sealant lightly to male NPT threads. This will prevent excess sealant from going into pipe. Excess sealant in pipe could result in clogged heater valves.

**WARNING:** Use pipe joint sealant that is resistant to liquid petroleum (LP) gas.

Install sediment trap in supply line as shown in Figure 15. Locate sediment trap where it is within reach for cleaning. Locate sediment trap where trapped matter is not likely to freeze. A sediment trap traps moisture and contaminants. This keeps them from going into heater controls. If sediment trap is not installed or is installed wrong, heater may not run properly.

**IMPORTANT:** Hold the pressure regulator with wrench when connecting it to gas piping and/or fittings. Do not over tighten pipe connection to regulator. The regulator body could be damaged.

**WARNING:** Never use an open flame to check for a leak. Apply a noncorrosive leak detection fluid to all joints. Bubbles forming show a leak. Correct all leaks at once.

**WARNING:** Test all gas piping and connections, internal and external to unit, for leaks after installing or servicing. Correct all leaks at once.



# INSTALLATION

*Continued*

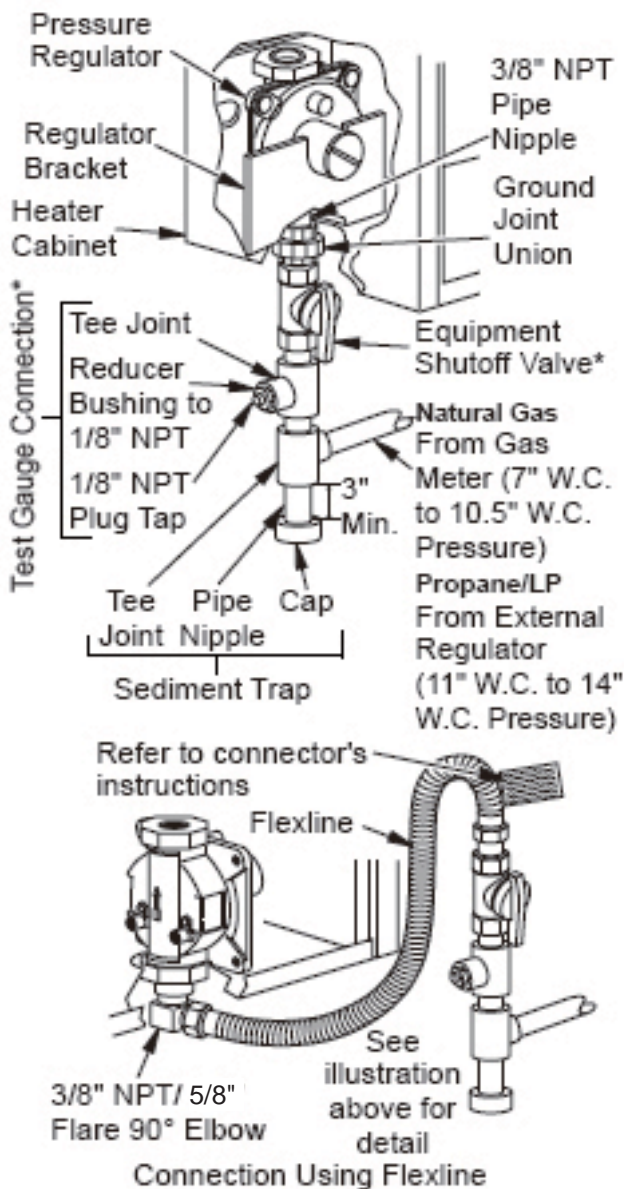

**Figure 14 - Gas Connection**

\* An CSA design-certified equipment shutoff valve with 1/8" NPT tap is an acceptable alternative to test gauge connection. Purchase the optional CSA design-certified equipment shutoff valve from your dealer.

## CHECKING GAS CONNECTIONS

**CAUTION:** For propane/LP gas, make sure external regulator has been installed between propane/LP supply and heater. See guidelines under *Connecting to Gas Supply*, page 11.

## PRESSURE TESTING GAS SUPPLY PIPING SYSTEM

### Test Pressures In Excess Of 1/2 PSIG (3.5 kPa)

1. Disconnect appliance with its appliance main gas valve (control valve) and equipment shutoff valve from gas supply piping system. Pressures in excess of 1/2 psig will damage heater regulator.
2. Cap off open end of gas pipe where equipment shutoff valve was connected.
3. Pressurize supply piping system by either opening propane/LP supply tank valve for propane/LP gas or opening main gas valve located on or near gas meter for natural gas or using compressed air.
4. Check all joints of gas supply piping system. Apply a noncorrosive leak detection fluid to all joints. Bubbles forming show a leak.
5. Correct all leaks at once.
6. Reconnect heater and equipment shutoff valve to gas supply. Check reconnected fittings for leaks.

### Test Pressures Equal To or Less Than 1/2 PSIG (3.5 kPa)

1. Close equipment shutoff valve (see Figure 15).
2. Pressurize supply piping system by either opening propane/LP supply tank valve for propane/LP gas or opening main gas valve located on or near gas meter for natural gas or using compressed air.
3. Check all joints from gas meter for natural gas (see Figure 16 on page 16) or propane/LP supply tank for propane/LP gas, to equipment shutoff valve (see Figure 17 on page 16)). Apply a noncorrosive leak detection fluid to all joints. Bubbles forming show a leak.
4. Correct all leaks at once.

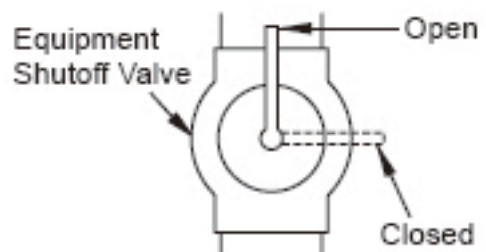

**Figure 15 - Equipment Shutoff Valve**

# INSTALLATION

*Continued*

## PRESSURE TESTING HEATER GAS CONNECTIONS

1. Open equipment shutoff valve (see Figure 15).
2. For natural gas, open main gas valve located on or near gas meter. For propane/LP gas open propane/LP supply tank valve.
3. Make sure control knob of heater is in the OFF position.
4. Check all joints from equipment shutoff valve to gas valve (see Figure 16 or 17).  
Apply a noncorrosive leak detection fluid to all joints. Bubbles forming show a leak.
5. Correct all leaks at once.
6. Light heater (see Operating Heater, page 17).  
Check all other internal joints for leaks.
7. Turn off heater (see To Turn Off Gas to Appliance, page 18).
8. Replace front panel.

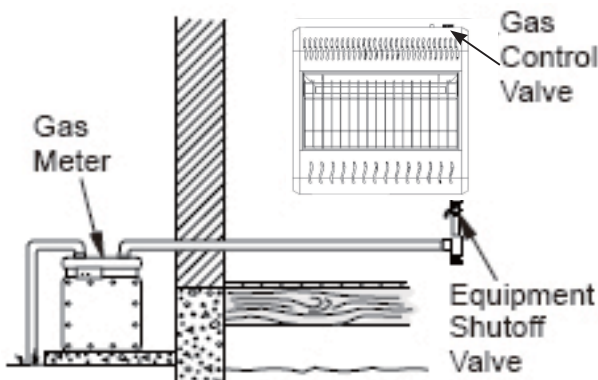

**Figure 16 - Checking Gas Joints for Natural Gas**

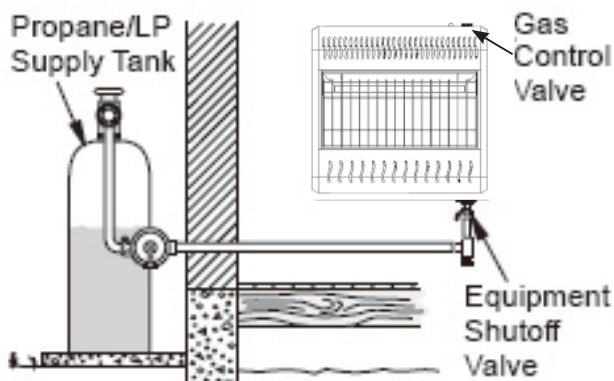

**Figure 17 - Checking Gas Joints for Propane/LP Gas**

## CONNECTING TO ELECTRICAL SUPPLY

(Only for Model IWH16 and IWH26)

**⚠ WARNING:** Fan accessory must be grounded. Fan comes with a three-prong, grounding plug as shown in Figure 18. The plug is your protection against electrical shock. Plug it into a standard, three-hole, grounded outlet. If cord needs replacing, use only a cord with a three-prong, grounding plug.

**⚠ CAUTION:** Label all wires prior to disconnection when servicing controls. Wiring errors can cause improper and dangerous operation (see page 21).

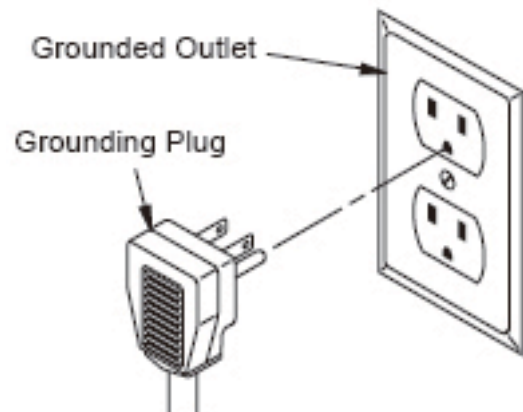

**Figure 18 - Grounding Plug**

## EXTENSION CORD

Use extension cord if needed. The cord must have a three-prong, grounding plug and a three-hole receptacle. Make sure cord is in good shape. It must be heavy enough to carry the current needed. An undersized cord will cause a drop in line voltage. This will result in loss of power and overheating. Use a No.16 AWG cord for lengths less than 50 feet (15.24 m).

**⚠ CAUTION:** Verify proper operation after servicing.

# INSTALLATION

*Continued*

## LP to NG Conversion Operation

1. Before gas conversion, remove knob lock by removing screw. (See Figure 19 & 20)
2. The knob is in the LP position (See Figure 23 on page 16). For NATURAL GAS, push the knob and turn clockwise until the knob locks into the NG position (See Figure 22 on page 16). The selection valve must be locked in the NG position. DO NOT operate the heater between the locked positions.
3. Remove the cap by hand from the regulator and now the white plastic screw is in the LP position (See Figure 21-1).
4. Remove the white plastic screw from the cap (See Figure 21-2).
5. Turn it over (See Figure 21-3) and reinstall it on the cap (See Figure 21-4). Make sure the white plastic screw is installed on the cap tightly.
6. Replace the cap on the regulator.
7. After gas conversion, make sure to replace knob lock and the screw.

**⚠ WARNING: Only a qualified installer or service technician can perform gas selection and connecting to gas supply.**

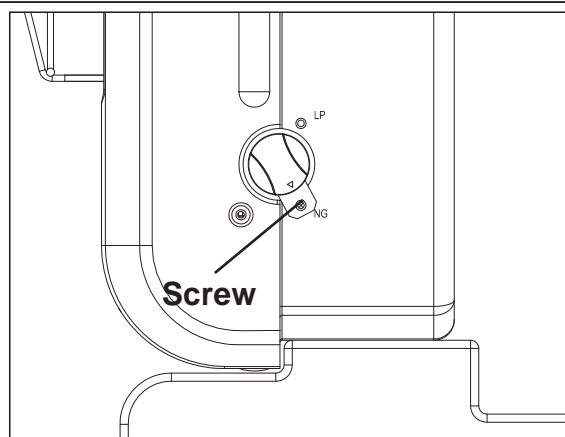

**Figure 19 - Remove Screw**

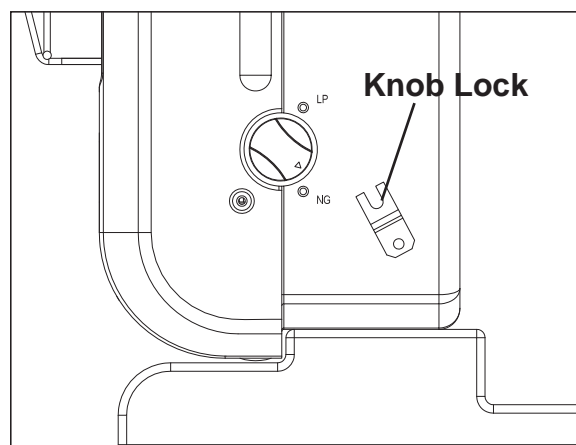

**Figure 20 - Remove Lock**

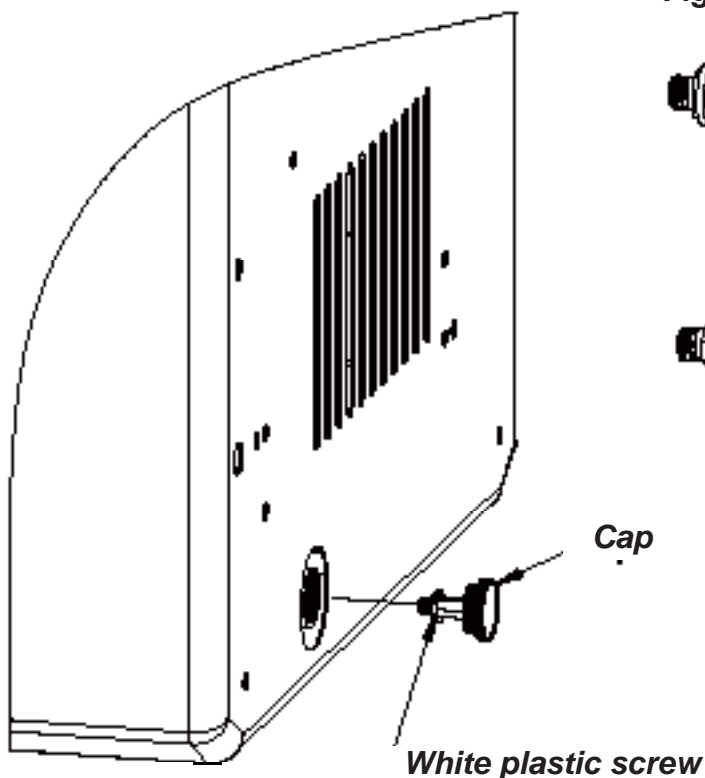

**Figure 21-1**

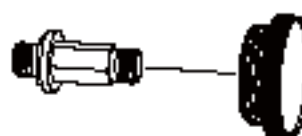

**Figure 21-2**

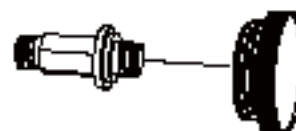

**Figure 21-3**

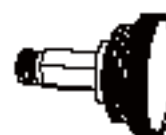

**Figure 21-4**

**Figure 21 - Setting Regulator to change from Propane/LP to Natural Gas Supply**

# INSTALLATION

Continued

## NG to LP Conversion Operation

1. Before gas conversion, remove knob lock by removing screw. (See Figure 19 & 20)
2. Before changing, the knob is in the NG position (See Figure 22). For Propane/LP GAS, push the knob and turn counterclockwise  until the knob locks into the LP position (See Figure 23). The selection valve must be locked in the LP position. DO NOT operate the heater between the locked positions.
3. Remove the cap by hand from the regulator and now the white plastic screw is in the NG position (See Figure 24-1).
4. Remove the white plastic screw from the cap (See Figure 24-2).
5. Turn it over (See Figure 24-3) and reinstall it on the cap (See Figure 24-4). Make sure the white plastic screw is installed on the cap tightly.
6. Replace the cap on the regulator.
7. After gas conversion, make sure to replace knob lock and the screw.

 **WARNING:** Only a qualified installer or service technician can perform gas selection and connecting to gas supply.

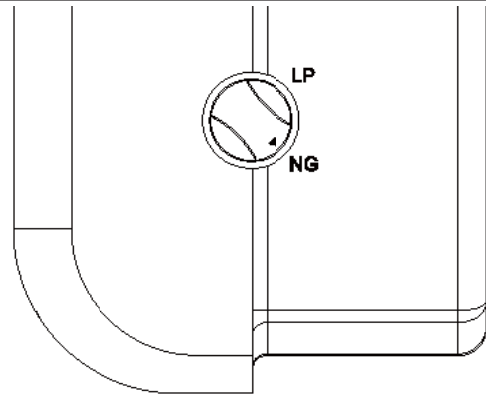

**Figure 22 - NG Position**

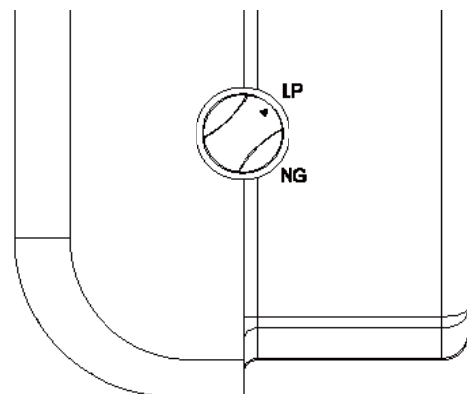

**Figure 23 - LP Position**

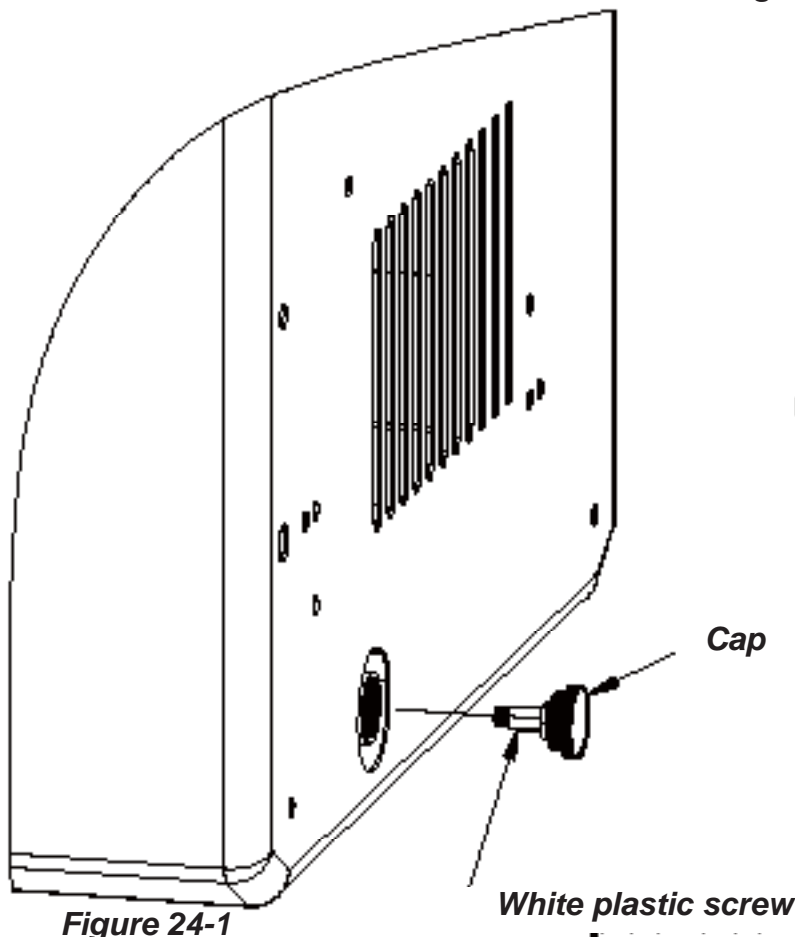

**Figure 24-1**

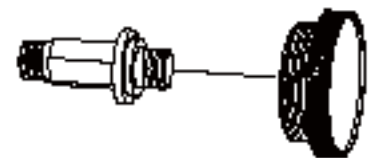

**Figure 24-2**

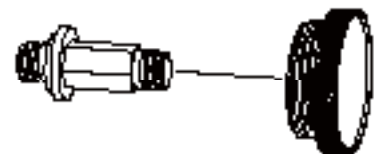

**Figure 24-3**

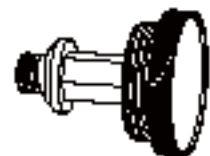

**Figure 24-4**

**Figure 24 - Setting Regulator to change from Natural Gas to Propane/LP Supply**



# OPERATING HEATER

FOR YOUR SAFETY READ  
BEFORE LIGHTING



**⚠ WARNING: If you do not follow these instructions exactly, a fire or explosion may result causing property damage, personal injury or loss of life.**

- A. This appliance has a pilot which must be lit by hand. When lighting the pilot, follow these instructions exactly.
- B. BEFORE LIGHTING, smell all around the appliance area for gas. Be sure to smell next to the floor because some gas is heavier than air and will settle on the floor.
- WHAT TO DO IF YOU SMELL GAS
- Do not try to light any appliance.
  - Do not touch any electric switch; do not use any phone in your building.
  - Immediately call your gas supplier from a neighbor's phone. Follow the gas supplier's instructions.
  - If you cannot reach your gas supplier, call the fire department.
- C. Use only your hand to push in or turn the gas control knob. Never use tools. If the knob will not push in or turn by hand, don't try to repair it, call a qualified service technician. Force or attempted repair may result in a fire or explosion.
- D. Do not use this appliance if any part has been under water. Immediately call a qualified service technician to inspect the appliance and to replace any part of the control system and any gas control which has been under water.

## LIGHTING INSTRUCTIONS

1. STOP! Read the safety information above.
2. Make sure equipment shutoff valve is fully open.
3. Turn control knob clockwise  to the OFF position (see Figure 25).
4. Wait five (5) minutes to clear out any gas. Then smell for gas, including near the

floor. If you smell gas, STOP! Follow "B" in the safety information, page 19. If you don't smell gas, go to the next step.

5. Turn control knob counterclockwise  to the PILOT position. Press in control knob for five (5) seconds.  
Note: You may be running this fireplace for the first time after hooking up to gas supply. If so, the control knob may need to be pressed in for 30 seconds or more. This will allow air to bleed from the gas system.
  - If control knob does not pop out when released, contact a qualified service person or gas supplier for repairs.
6. With control knob pressed in, press and release ignitor button. This will light pilot. The pilot is attached to the front burner. If needed, keep pressing ignitor button until pilot lights.  
Note: If pilot does not stay lit, refer to Troubleshooting, page 21. Also, contact a qualified service person or gas supplier for repairs. Until repairs are made, light pilot with match. To light pilot with match, see Manual Lighting Procedure, page 18.
7. Keep control knob pressed in for 30 seconds after lighting pilot. After 30 seconds, release control knob.  
Note: If pilot goes out, repeat steps 3 through 7.
8. Turn control knob counterclockwise to desired heating level. The burner should light. Set control knob to any heat level between HI and LO.
9. To leave pilot lit and shut off burners only, turn control knob clockwise  to the PILOT position.

**⚠ CAUTION: Do not try to adjust heating levels by using the equipment shutoff valve.**

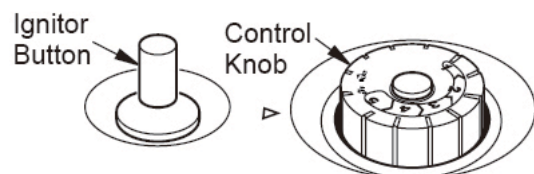

**Figure 25 - Control Knob In The OFF Position**

# OPERATING HEATER

*Continued*

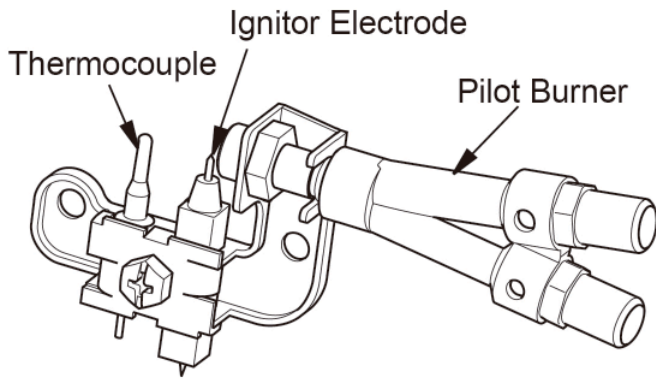

**Figure 26 - Pilot**

TO SELECT HEATING LEVEL

**WARNING:** When running heater, set control knob at locked positions. Never set control knob between locked positions. Poor combustion and higher levels of carbon monoxide may result.

**CAUTION:** Do not try to adjust heating levels by using the equipment shutoff valve.

Turn thermostat control knob counterclockwise to the desired heating level. The main burner should light. Set control knob to any heat level between 1 and 5 (see Figure 27).

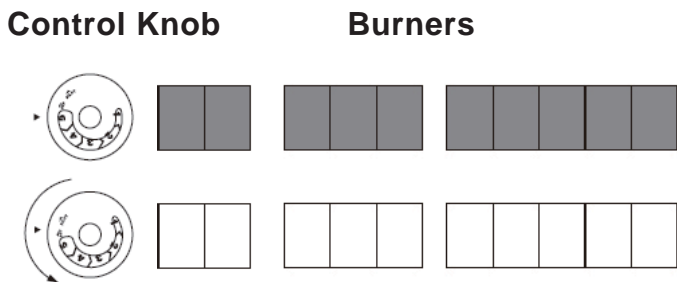

**Figure 27 - Burner Patterns**

TO TURN OFF GAS TO APPLIANCE

## Shutting Off Heater

1. Turn control knob clockwise to the OFF position.
2. Turn off all electric power to the appliance if service is to be performed.

## Shutting Off Burner Only (pilot stays lit)

Turn control knob clockwise to the PILOT position.

MANUAL LIGHTING PROCEDURE

1. Remove front panel (see Figure 6, page 9).
2. Follow steps 1 through 7 under Lighting Instructions, page 16.
3. With control knob pressed in, strike match. Hold match to pilot until pilot lights.
4. Keep control knob pressed in for 30 seconds after lighting pilot. After 30 seconds, release control knob. Now follow step 9, under Lighting Instructions.
5. Replace front panel.

THERMOSTAT CONTROL OPERATION

The thermostatic control used on these models differs from standard thermostats. Standard thermostats simply turn the burner on and off. The thermostat used on this heater senses the room temperature. At times, the room may exceed the set temperature. If so, the burner will shut off. The burner will cycle back on when room temperature drops below the set temperature. The control knob can be set to any heat level between 1 and 5. All burners will turn off and on.

Note: The thermostat sensing bulb measures the temperature of air near the heater cabinet. This may not always agree with room temperature (depending on housing construction, installation location, room size, open air temperatures, etc.). Frequent use of your heater will let you determine your own comfort levels.

# INSPECTING HEATER

## OPERATING BLOWER

This heater has a thermostatic blower that will automatically turn ON or OFF.

Note: Your heater and thermostat blower will not turn on and off at the same time. The heater may run for several minutes before the blower turns on. After the heater modulates to the pilot position, the blower will continue to run. The blower will shut off after the heater cabinet temperature decreases.

Note: It is safe to operate heater with blower turned off. However, the blower helps distribute heated air from the heater.

Check pilot flame pattern and burner flame pattern often.

### PILOT FLAME PATTERN

Figure 28 shows a correct pilot flame pattern.

Figure 29 shows an incorrect pilot flame pattern. The incorrect pilot flame is not touching the thermocouple. This will cause the thermocouple to cool. When the thermocouple cools, the heater will shut down.

If pilot flame pattern is incorrect, as shown in Figure 29

- turn heater off (see To Turn Off Gas to Appliance, page 18)
- see Troubleshooting, page 21

Note: The pilot flame on natural gas units will have a slight curve, but flame should be blue and have no yellow or orange color.

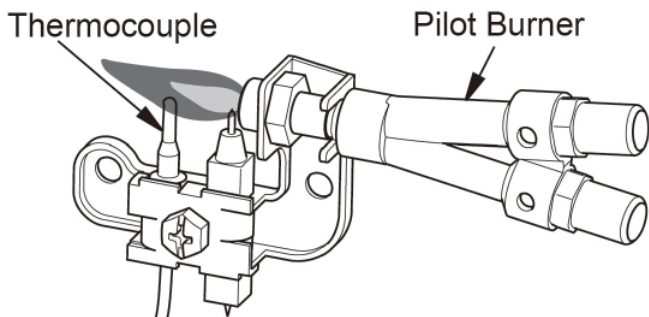

**Figure 28 - Correct Pilot Flame Pattern**

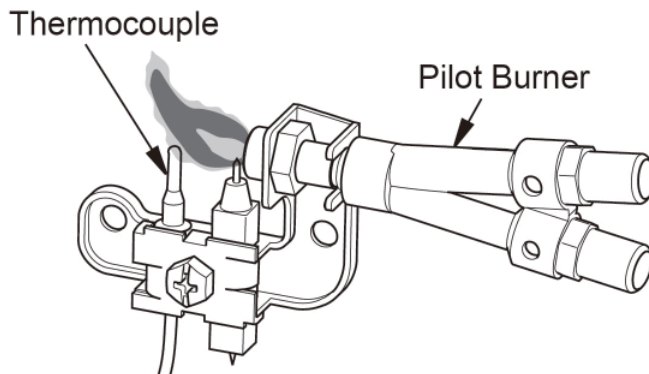

**Figure 29 - Incorrect Pilot Flame Pattern**

### BURNER FLAME PATTERN

Figure 30 shows a correct burner flame pattern. Figure 31 shows an incorrect burner flame pattern.

If burner flame pattern is incorrect, as shown in Figure 31

- turn heater off (see To Turn Off Gas to Appliance, page 18)
- see Troubleshooting, page 21

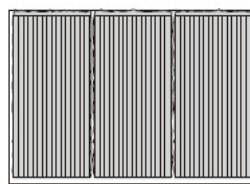

**Figure 30 - Correct Burner Flame Pattern**

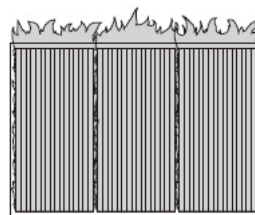

**Figure 31 - Incorrect Burner Flame Pattern**

## CLEANING AND MAINTENANCE

**⚠ WARNING:** Turn off heater and let cool before cleaning.

**⚠ CAUTION:** you must keep control areas, burner and circulating air passageways of heater clean. Inspect these areas of heater before each use. Have heater inspected yearly by a qualified service person. Heater may need more frequent cleaning due to excessive lint from carpeting, bedding material, pet hair, etc.

**⚠ WARNING:** Failure to keep the primary air opening(s) of the burner(s) clean may result in sooting and property damage.

### ODS/PILOT AND BURNER

Use a vacuum cleaner, pressurized air or small, soft bristled brush to clean.

### BURNER PILOT AIR INLET

The primary air inlet holes allow the proper amount of air to mix with the gas. This provides a clean burning flame. Keep these holes clear of dust, dirt and lint. Clean these air inlet holes prior to each heating season. Blocked air holes will create soot. We recommend that you clean the unit every three months during operation and have heater inspected yearly by a qualified service person.

We also recommend that you keep the burner tube and pilot assembly clean and free of dust and dirt. To clean these parts we recommend using compressed air no greater than 30 PSI. Your local computer store, hardware store or home center may carry compressed air in a can. If using compressed air in a can, please follow the directions on the can. If you don't follow directions on the can, you could damage the pilot assembly.

1. Shut off the unit, including the pilot. Allow the unit to cool for at least thirty minutes.
2. Inspect burner, pilot for dust and dirt.
3. Blow air through the ports/slots and holes in the burner.

4. Never insert objects into the pilot tube. Clean the pilot assembly also. A yellow tip on the pilot flame indicates dust and dirt in the pilot assembly. There is a small pilot air inlet about two inches from where the pilot flame comes out of the pilot assembly (see Figure 32). With the unit off, lightly blow air through the air inlet. You may blow through a drinking straw if compressed air is not available.

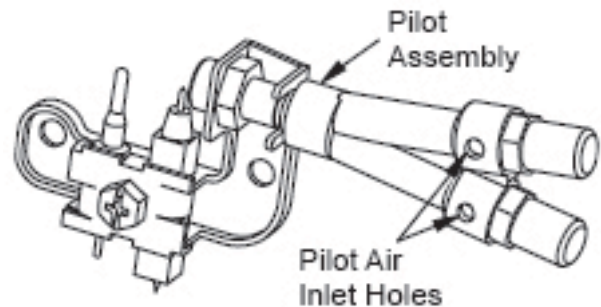

*Figure 32 - Pilot Air Inlet*

## CABINET

### Air Passageways

Use pressurized air to clean.

### Exterior

Use a soft cloth dampened with a mild soap and water mixture. Wipe the cabinet to remove dust.



# TROUBLESHOOTING

**⚠ WARNING: Turn off and unplug heater and let cool before servicing. Only a qualified service person should service and repair heater.**

**⚠ CAUTION: Never use a wire, needle or similar object to clean ODS/pilot. This can damage ODS/pilot unit.**

Note: All troubleshooting items are listed in order of operation.

OBSERVED PROBLEM	POSSIBLE CAUSE	REMEDY
When ignitor button is pressed in, there is no spark at ODS/pilot	<ol style="list-style-type: none"> <li>1. Ignitor electrode positioned wrong</li> <li>2. Ignitor electrode broken</li> <li>3. Ignitor electrode not connected to ignitor cable</li> <li>4. Ignitor cable pinched or wet</li> <li>5. Broken ignitor cable</li> <li>6. Bad ignitor</li> <li>7. Piezo ignitor nut is loose</li> </ol>	<ol style="list-style-type: none"> <li>1. Replace pilot assembly</li> <li>2. Replace pilot assembly</li> <li>3. Reconnect ignitor cable</li> <li>4. Free ignitor cable if pinched by any metal or tubing. Keep ignitor cable dry</li> <li>5. Replace ignitor cable</li> <li>6. Replace ignitor</li> <li>7. Tighten nut holding piezo ignitor. Nut is located inside heater cabinet at top</li> </ol>
When ignitor button is pressed in, there is a spark at ODS/Pilot but no ignition	<ol style="list-style-type: none"> <li>1. Gas supply turned off or equipment shutoff valve closed</li> <li>2. Control knob is not in pilot position</li> <li>3. Control knob not fully pressed in while pressing ignitor button</li> <li>4. Air in gas lines when installed</li> <li>5. Depleted gas supply (propane/LP gas)</li> <li>6. ODS/pilot is clogged</li> <li>7. Gas regulator setting is not correct</li> </ol>	<ol style="list-style-type: none"> <li>1. Turn on gas supply or open equipment shutoff valve</li> <li>2. Turn control knob to pilot position</li> <li>3. Turn to PILOT/IGN position. Fully press in control knob while pressing ignitor button</li> <li>4. Continue holding down control knob. Repeat igniting operation until air is removed</li> <li>5. Contact local propane/LP gas company</li> <li>6. Clean ODS/pilot (See <i>Cleaning and Maintenance</i>, page 17) or replace ODS/pilot assembly</li> <li>7. Replace gas regulator</li> </ol>
Moisture/condensation noticed on windows	<ol style="list-style-type: none"> <li>1. Not enough combustion/ventilation air</li> </ol>	<ol style="list-style-type: none"> <li>1. Refer to Air for Combustion and Ventilation requirements (page 5)</li> </ol>

---

# TROUBLESHOOTING

*Continued*

<b>OBSERVED PROBLEM</b>	<b>POSSIBLE CAUSE</b>	<b>REMEDY</b>
ODS/pilot lights but flame goes out when control knob is released	<ol style="list-style-type: none"><li>1. Control knob not fully pressed in</li><li>2. Control knob not pressed in long enough</li><li>3. Equipment shutoff valve not fully open</li><li>4. Thermocouple connection loose at control valve</li><li>5. Pilot flame not touching thermocouple, which allows thermocouple to cool, causing pilot flame to go out. This problem could be caused by one or both of the following:<ol style="list-style-type: none"><li>A) Low gas pressure</li><li>B) Dirty or partially clogged ODS/pilot</li></ol></li><li>6. Thermocouple damaged</li><li>7. Control valve damaged</li><li>8. Safety interlock system has been triggered</li></ol>	<ol style="list-style-type: none"><li>1. Press in control knob fully</li><li>2. After ODS/pilot lights, keep control knob pressed in 30 seconds</li><li>3. Fully open equipment shut-off valve</li><li>4. Hand tighten until snug, then tighten 1/4 turn more</li><li>5. A) Contact local natural or propane/LP gas company B) Clean ODS/pilot (see Cleaning and Maintenance, page 17) or replace ODS/pilot assembly</li><li>6. Replace pilot assembly</li><li>7. Replace control valve</li><li>8. Wait one minute for safety interlock system to reset. Repeat ignition operation</li></ol>
Burner(s) does not light after ODS/pilot is lit	<ol style="list-style-type: none"><li>1. Burner Orifice(s) is clogged</li><li>2. Inlet gas pressure is too low</li></ol>	<ol style="list-style-type: none"><li>1. Clean burner orifice(s) (see Cleaning and Maintenance, page 17) or replace burner orifice(s)</li><li>2. Contact local natural or propane/LP gas company</li></ol>
Delayed ignition of burner(s)	<ol style="list-style-type: none"><li>1. Manifold pressure is too low</li><li>2. Burner Orifice(s) is clogged</li></ol>	<ol style="list-style-type: none"><li>1. Contact local natural or propane/LP gas company</li><li>2. Clean burner orifice(s) (see Cleaning and Maintenance, page 17) or replace burner orifice(s)</li></ol>
Burner backfiring during combustion	<ol style="list-style-type: none"><li>1. Burner orifice(s) is clogged or damaged</li><li>2. Burner damaged</li><li>3. Gas regulator defective</li></ol>	<ol style="list-style-type: none"><li>1. Clean burner orifice(s) (see Cleaning and Maintenance, page 17) or replace burner orifice(s)</li><li>2. Replace burner</li><li>3. Replace gas regulator</li></ol>
Burner plaque(s) does not glow	<ol style="list-style-type: none"><li>1. Plaque damaged</li><li>2. Inlet gas pressure is too low</li><li>3. Control knob set between locked positions</li></ol>	<ol style="list-style-type: none"><li>1. Replace burner</li><li>2. Contact local natural or propane/LP gas company</li><li>3. Turn control knob until it locks at desired setting</li></ol>
Heater produces a clicking/ticking noise just after burner is lit or shut off	<ol style="list-style-type: none"><li>1. Metal expanding while heating or contracting while cooling</li></ol>	<ol style="list-style-type: none"><li>1. This is normal with most heaters. If noise is excessive, contact qualified service person</li></ol>
Slight smoke or odor during initial operation	<ol style="list-style-type: none"><li>1. Residues from manufacturing processes</li></ol>	<ol style="list-style-type: none"><li>1. Problem will stop after a few hours of operation</li></ol>

# TROUBLESHOOTING

*Continued*



**WARNING: If you smell gas**

- **Shut off gas supply.**
- **Do not try to light any appliance.**
- **Do not touch any electrical switch; do not use any phone in your building.**
- **Immediately call your gas supplier from a neighbor's phone. Follow the gas supplier's instructions.**
- **If you cannot reach your gas supplier, call the fire department.**

*IMPORTANT:* Operating heater where impurities in air exist may create odors. Cleaning supplies, paint, paint remover, cigarette smoke, cements and glues, new carpet or textiles, etc., create fumes. These fumes may mix with combustion air and create odors.

<b>OBSERVED PROBLEM</b>	<b>POSSIBLE CAUSE</b>	<b>REMEDY</b>
White powder residue forming within burner box or on adjacent walls or furniture	1. When heated, vapors from furniture polish, wax, carpet cleaner, etc., may turn into white powder residue	1. Turn heater off when using furniture polish, wax, carpet cleaners or similar products
Heater shuts off in use (ODS operates)	1. Not enough fresh air is available 2. Low line pressure 3. ODS/pilot is partially clogged	1. Open window and/or door for ventilation 2. Contact local natural or propane/LP gas company 3. Clean ODS/pilot ( See Cleaning and Maintenance, page 17)
Heater produces unwanted odors	1. Heater burning vapors from paint, hair spray, glues, etc. See <b>IMPORTANT</b> statement above 2. Low fuel supply (propane/LP gas only) 3. Gas leak. <b>See Warning statement at top of page</b>	1. Ventilate room. Stop using odor causing products while heater is running 2. Refill supply tank 3. Locate and correct all leaks (see Checking Gas Connections, page 12)
Gas odor even when control knob is in OFF position	1. Gas leak. See Warning statement at top of page 2. Control valve defective	1. Locate and correct all leaks (see Checking Gas Connections, page 12) 2. Replace control valve
Gas odor during combustion	1. Foreign matter between control valve and burner 2. Gas leak. See Warning statement at top of page	1. Foreign matter between control valve and burner 2. Gas leak. See Warning statement at top of page
Heater produces a whistling noise when burner is lit	1. Air in gas line  2. Air passageways on heater blocked. 3. Dirty or partially clogged burner orifice	1. Operate burner until air is removed from line. Have gas line checked by local natural or propane/LP gas company 2. Observe minimum installation clearances (see Figure 4, page 8) 3. Clean burner (see Cleaning and Maintenance, page 17) or replace burner orifice

# SPECIFICATIONS

ITEM NO.	IWH10NLTB	IWH16NLTB	IWH26NLTB
Gas Type	Using Natural Gas		
Pressure Regulator Setting	4.5 in. W.C.	4.5 in. W.C.	4.5 in. W.C.
Inlet Gas Pressure (inches of water) For purposes of input adjustment			
Maximum	10.5 in.	10.5 in.	10.5 in.
Minimum	7 in.	7 in.	7 in.
BTU (available)	10,000	15,000	25,000
Gas Type	Using Propane Gas		
Pressure Regulator Setting	10 in. W.C.	10 in. W.C.	10 in. W.C.
Inlet Gas Pressure (inches of water) For purposes of input adjustment			
Maximum	14 in.	14 in.	14 in.
Minimum	11 in.	11 in.	11 in.
BTU (available)	10,000	18,000	28,000
Ignition	Piezo	Piezo	Piezo
Dimension, Inches (HxWxD)	15.4x22.5x12.1	18x26.3x12.1	25.6x26.3x12.1
Heater	17.9x23.4x11	20.1x27.2x11	28.1x27.2x11
Weight (Pounds)			
Heater	14.8	21.5	18.4
Shipping	18.1	25.5	31.5

Note: Dimensions listed are outer most points on the heater (includes control knobs and grill)

\* For purposes of input adjustment.

## WIRING DIAGRAM (Only for Model IWH16 and IWH26)

**⚠ WARNING:** Never attempt to service heater while it is plugged in, operating, or hot. Burns and electrical shock could result. Only a qualified service person should service or repair heater.

**⚠ CAUTION:** Label all wires prior to disconnection when servicing controls. Wiring errors can cause improper and dangerous operation. Verify proper operation after servicing.

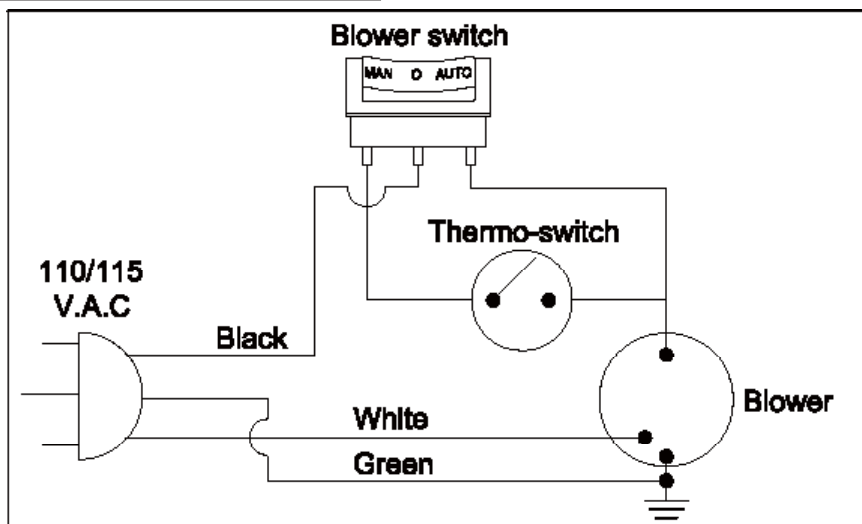

*Wiring Diagram*



# Replacement Parts

*Model: IWH10NLTB*

NO.	Part Description	Part NO.	Qty.
1	Shell Front - IR2	SBNCD00657A	1
2	Grill - IR2	RCOCC00012A	1
3	Burner Assembly - IR2	RCOZZ00391A	1
4	Regulator - DF	RCOZZ00568A	1
5	Dual Fuel ODS Pilot		1
6	Base Foot		2
7	Selection Valve Knob		1
8	Selection Valve - IR	RCOZZ00393A	2
9	Mounting Bracket - IR2	SBNCF00669A	1
10	Thermo-Valve Assembly	RCOZZ00396A	1
11	Piezo Ignitor	RCOZZ00395A	1
Not Shown			
	Hardware Assembly	SAS2200029A	1

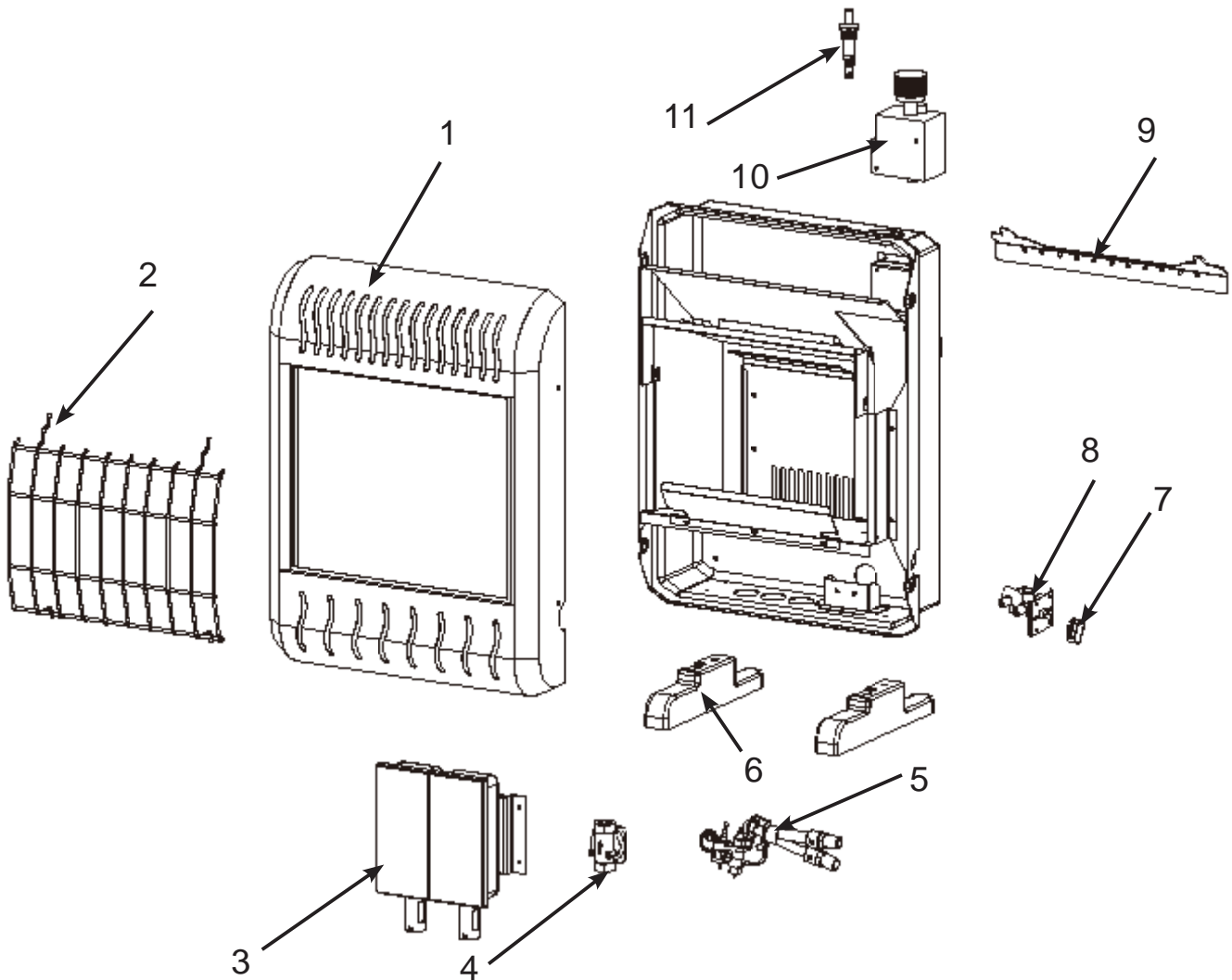

# Replacement Parts

*Model: IWH16NLTB*

NO.	Part Description	Part NO.	Qty.
1	Shell Front - IR3	SBNCD00659A	1
2	Grill - IR3	RCOCC00012B	1
3	Burner Assembly - IR3	RCOZZ00391B	1
4	Regulator - DF	RCOZZ00568A	1
5	Dual Fuel ODS Pilot		1
6	Base Foot		2
7	Selection Valve Knob		1
8	Selection Valve - IR	RCOZZ00393A	2
9	Mounting Bracket - IR3	SBNCF00670A	1
10	Thermo-Valve Assembly	RCOZZ00396A	1
11	Piezo Ignitor	RCOZZ00395A	1
12	Switch		1
13	Motor		1
14	Blade		1
15	Thermo - Switch	RCOZZ00446A	1
Not Shown			
	Hardware Assembly	SAS2200029A	1
	Power Cord		1

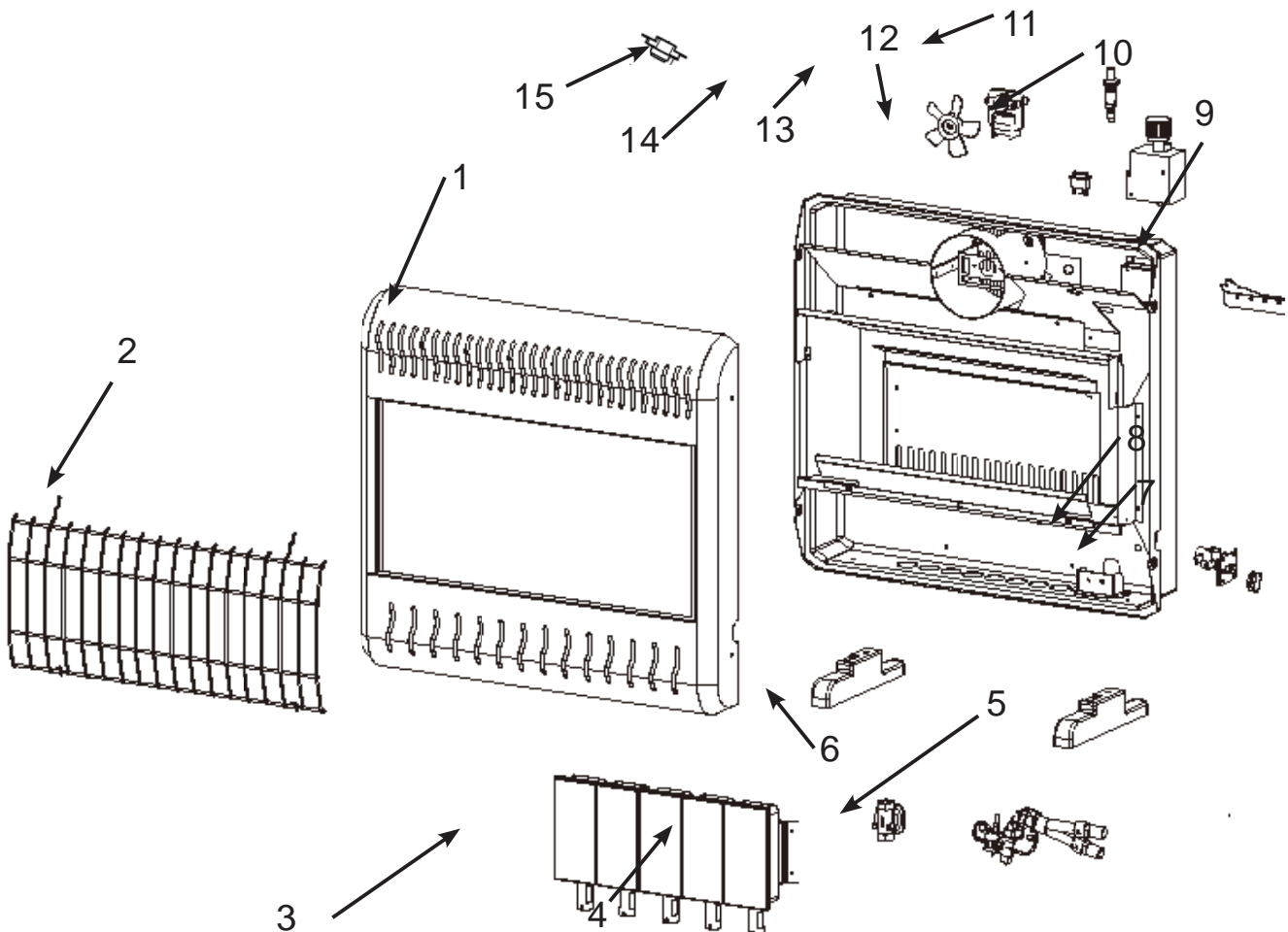

# Replacement Parts

*Model: IWH26NLTB*

NO.	Part Description	Part NO.	Qty.
1	Shell Front - IR5	SBNCD00661A	1
2	Grill - IR5	RCOCC00012C	1
3	Burner Assembly - IR5	RCOZZ00391C	1
4	Regulator - DF	RCOZZ00568A	1
5	Dual Fuel ODS Pilot		1
6	Base Foot		2
7	Selection Valve Knob		1
8	Selection Valve - IR	RCOZZ00393A	2
9	Mounting Bracket - IR3	SBNCF00670A	1
10	Thermo-Valve Assembly	RCOZZ00396A	1
11	Piezo Ignitor	RCOZZ00395A	1
12	Switch		1
13	Motor		1
14	Blade		1
15	Thermo - Switch	RCOZZ00446A	1
Not Shown			
	Hardware Assembly	SAS2200029A	1
	Power Cord		1

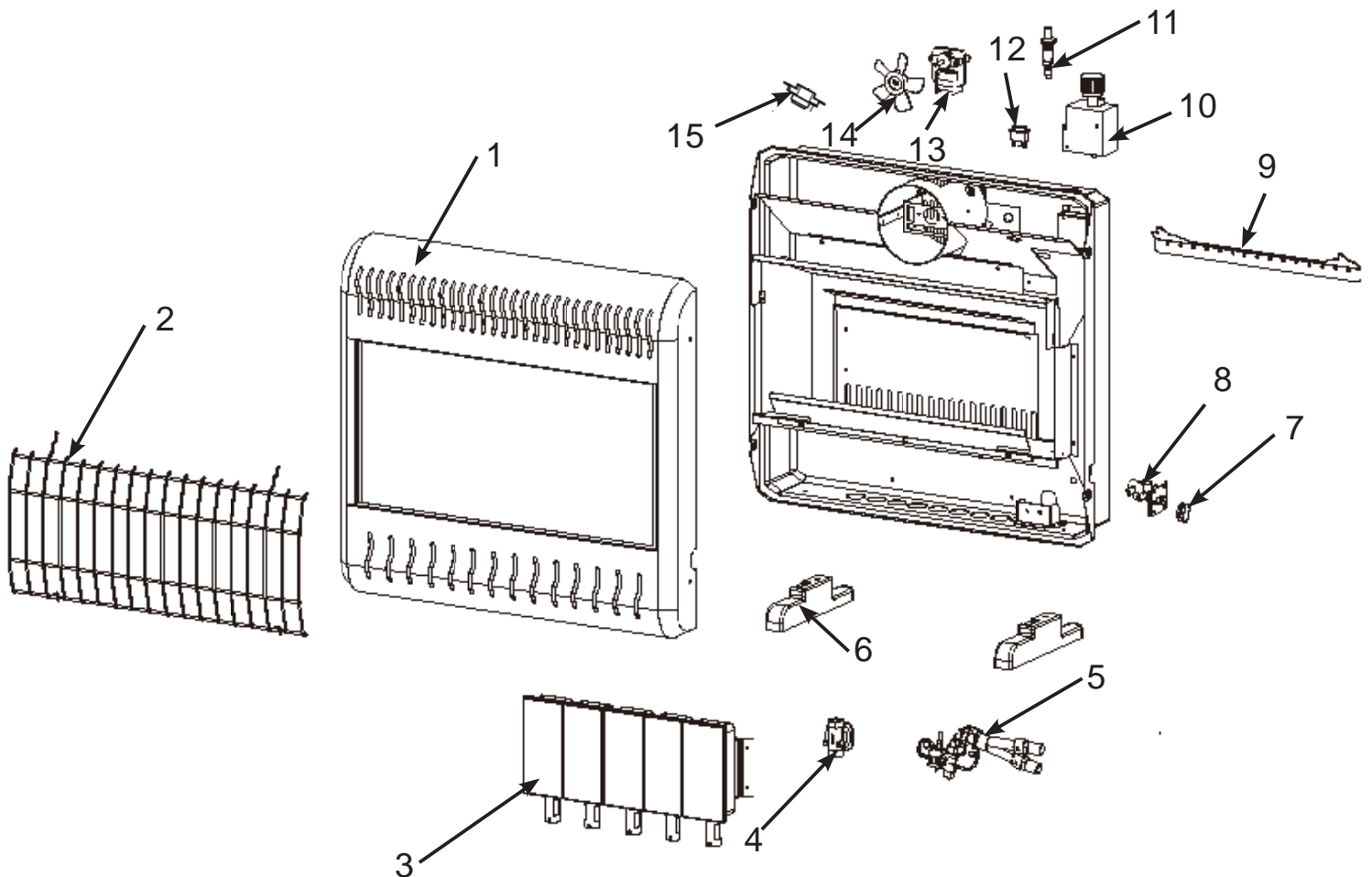

---

## REPLACEMENT PARTS

Note: Use only original replacement parts. This will protect your warranty coverage for parts replaced under warranty.

### PARTS UNDER WARRANTY

Contact authorized dealers of this product. If they can't supply original replacement part(s), call Sure Heat Products' Technical Service Department at (800) 229-5647.

When calling Sure Heat have ready

- your name
- your address
- model and serial numbers of your heater
- how heater was malfunctioning
- type of gas used (propane/LP or natural gas)
- purchase date

Usually, we will ask you to return the part to the factory.

### PARTS NOT UNDER WARRANTY

Contact authorized dealers of this product. If they can't supply original replacement part(s), either contact your nearest Parts Central or call Sure Heat Heating Products at (800) 229-5647 for referral information.

When calling Sure Heat, have ready

- model number of your heater
- the replacement part number

## SERVICE HINTS

When Gas Pressure Is Too Low

- pilot will not stay lit
- burner will have delayed ignition
- heater will not produce specified heat
- propane/LP gas supply may be low

You may feel your gas pressure is too low. If so, contact your local natural or propane/LP gas supplier.

Note: Use only original replacement parts. This will protect your warranty coverage for parts replaced under warranty.

## TECHNICAL SERVICE

You may have further questions about installation, operation or troubleshooting. If so, contact Sure Heat Heating Products' Technical Service Department at (800) 229-5647. When calling please have your model and serial numbers of your heater ready. You can also visit Sure Heat Heating Products' technical service web site at [www.sureheat.com](http://www.sureheat.com).



# LIMITED WARRANTY

Sure Heat Mfg. warrants that the components of this appliance are warranted free from defects in material and workmanship for two (2) years from the date of purchase. Sure Heat Mfg. at its option, will repair or replace this product or any component of the product found to be defective during the warranty period. Replacement will be made with a new manufactured product or component. If the product is no longer available, replacement may be made with a similar product of equal value. This warranty does not include transportation or shipping costs of any kind. This is your exclusive warranty.

This warranty is valid for the original retail purchaser from the date of initial retail purchase and is not transferable. Keep the original sales receipt. Proof of purchase is required to obtain warranty parts.

This warranty does not cover normal wear of parts such as scratches and dents of the components or damage resulting from any of the following:

- negligent use or misuse of the product, including exposing the product to chemicals or cleaning products not approved by Sure Heat Mfg.
- corrosion, rust or discoloring of any kind
- use or installation contrary to specified instructions and applicable building codes, including heating the product to temperatures above its rated specifications which can cause considerable warping
- disassembly, including removal of the product from a built-in installation
- damage resulting from accident, alteration, misuse, abuse, hostile environments, or improper installation
- repair or alteration
- acts of God, such as fire, flood hurricanes and tornadoes
- gas cylinders, propane tanks or other fuel delivery systems, including connections to a household fuel supply
- usage other than single-family household use such as commercial or industrial use
- minor warping or discoloration of parts, which is normal and not a defect under this warranty

## **DO NOT RETURN THIS PRODUCT TO THE PLACE OF PURCHASE**

If the appliance does not operate properly, first thoroughly carry out the instructions provided with the unit to ensure that the appliance is installed correctly and check the troubleshooting section in the use and care manual.

We recommend you return the warranty registration card so that you can be contacted with any questions of safety arise that could affect you. The return of the warranty registration card is not a condition for warranty coverage.

Because of continuing product improvement, these specifications are subject to change without notice.

If you have other questions or need replacement parts contact our  
Customer Service Hotline at (800) 229-5647 or  
visit our website at [www.sureheat.com](http://www.sureheat.com)

**Sure Heat Manufacturing, 1861 West Oak Parkway Marietta, GA 30062**